

Emiliana Pudjiarti

Faith-Inspired Interrelational Citizenship: a Key Driver for Cultivating Peace in The Indonesian Socio-Political Landscapes

 Quick Submit

 Quick Submit

 Universitas 17 Agustus 1945 Semarang

Document Details

Submission ID

trn:oid::1:2986361761

Submission Date

Aug 20, 2024, 5:46 AM GMT+7

Download Date

Aug 20, 2024, 1:33 PM GMT+7

File Name

Faith-Inspired_Interrelational.pdf

File Size

505.2 KB

20 Pages

10,296 Words

61,927 Characters

4% Overall Similarity

The combined total of all matches, including overlapping sources, for each database.

Filtered from the Report

- ▶ Bibliography

Match Groups

- 14 Not Cited or Quoted 4%**
Matches with neither in-text citation nor quotation marks
- 1 Missing Quotations 0%**
Matches that are still very similar to source material
- 0 Missing Citation 0%**
Matches that have quotation marks, but no in-text citation
- 0 Cited and Quoted 0%**
Matches with in-text citation present, but no quotation marks

Top Sources

- 0% Internet sources
- 0% Publications
- 4% Submitted works (Student Papers)

Integrity Flags

0 Integrity Flags for Review

No suspicious text manipulations found.

Our system's algorithms look deeply at a document for any inconsistencies that would set it apart from a normal submission. If we notice something strange, we flag it for you to review.

A Flag is not necessarily an indicator of a problem. However, we'd recommend you focus your attention there for further review.

Match Groups

- **14 Not Cited or Quoted 4%**
Matches with neither in-text citation nor quotation marks
- **1 Missing Quotations 0%**
Matches that are still very similar to source material
- **0 Missing Citation 0%**
Matches that have quotation marks, but no in-text citation
- **0 Cited and Quoted 0%**
Matches with in-text citation present, but no quotation marks

Top Sources

- 0% Internet sources
- 0% Publications
- 4% Submitted works (Student Papers)

Top Sources

The sources with the highest number of matches within the submission. Overlapping sources will not be displayed.

1	Student papers		2%
<hr/>			
2	Student papers		
<hr/>			
2	Student papers		
<hr/>			
2	Student papers		
<hr/>			
3	Student papers		
<hr/>			
3	Student papers		
<hr/>			
4	Student papers		
<hr/>			
5	Student papers		
<hr/>			
6	Student papers		
<hr/>			
7	Student papers		
<hr/>			

Faith-Inspired Interrelational Citizenship: a Key Driver for Cultivating Peace in The Indonesian Socio-Political Landscapes

Antonius Denny Firmanto^{1,2,*}, Emiliana Sri Pudjiarti³, Alphonsus Tjatur Raharso¹, Edison R.L. Tinambunan¹



Author Note

Antonius Denny Firmanto   ^{1,2,*} <https://orcid.org/0000-0001-7590-5654>

¹Sekolah Tinggi Filsafat Teologi Widya Sasana, Malang, East Java 65146, Indonesia

²Pontificia Università Urbaniana, Via Urbano, 00165 Rome, Italy

fantoniusedenny@gmail.com

Emiliana Sri Pudjiarti   ³ <https://orcid.org/0000-0002-7612-1031>



³Universitas 17 Agustus 1945 Semarang, Central Java 50133, Indonesia

emiliana-sripudjiarti@untagsmg.ac.id

Alphonsus Tjatur Raharso   ¹ <https://orcid.org/0009-0004-0787-7574>

¹Sekolah Tinggi Filsafat Teologi Widya Sasana, Malang, East Java 65146, Indonesia

alphonsustjaturraharso@gmail.com

Edison R.L. Tinambunan   ¹ <https://orcid.org/0000-0003-1656-927X>

¹Sekolah Tinggi Filsafat Teologi Widya Sasana, Malang, East Java 65146, Indonesia

edisontinambunan750@gmail.com

We have no known conflict of interest to disclose.

Correspondence concerning this article should be addressed to Antonius Denny Firmanto

*Email: fantoniusedenny@gmail.com

December 2023

Faith-Inspired Interrelational Citizenship: a Key Driver for Cultivating Peace in The Indonesian Socio-Political Landscapes

Antonius Denny Firmanto^{1,2,*}, Emiliana Sri Pudjiarti³, Alphonsus Tjatur Raharso¹, Edison R.L. Tinambunan¹

¹Sekolah Tinggi Filsafat Teologi Widya Sasana, Malang, East Java 65146, Indonesia

²Pontificia Università Urbaniana, Via Urbano, 00165 Rome, Italy

³Universitas 17 Agustus 1945 Semarang, Central Java 50133, Indonesia

*Email Correspondence: fantoniusedenny@gmail.com

Abstract: This study analyzed the influence of awareness of humanitarian mission vocations, meaningful living, prosocial engagement, and spiritual engagement on faith-inspired inter-relational citizenship and local and religious values. The findings showed the positive and significant impact of these aspects in shaping values and deep relational relationships. The integration of religious values in education was recognized as a means to increase global awareness, empathy, and intercultural cooperation. However, the potential for exclusivity and value conflicts was also recognized. Future research recommendations engaged broader stakeholders and measured the real impact on student behavior. Weaknesses of this study included limitations in participants and the generalizability of findings. Overcoming these limitations could enrich our understanding of the role of integrating religious values in shaping responsible and competitive global citizens.

Keywords: awareness of mission calls for humanity; faith-inspired interrelational citizenship; meaningful life; prosocial engagement; spiritual engagement

1. Introduction

Disruption is the theme of the Industrial Revolution Era 4.0 and Society 5.0. (Barokah & Hertanto, 2020). Turbulent conditions are one of the fruits of disruption (Knudsen et al. 2021). It is suspected that turbulent conditions have characteristics of volatile, uncertain, complex, ambiguous, irregular, and random will color the process of the political year ahead of the 2024 elections (Ramus et al. 2018). The prediction arises from experience di English (Ikmal & Arifin, 2020) and abroad (Buigut & Masinde, 2021; Wei et al., 2020). The turbulence of the political field affects the economic, social, and resilience of society. Identity politics and societal polarization are two possible strategies that emerge in electoral contestation. Social turbulence: a kind of irregular and random social movement, in the form of political discourse that develops without direction, economic discourse haunted by recession and inflation, social discourse tainted by violence, and cultural discourse without value (Arshad et al. 2020). Turbulence consumes social energy because its content is a commotion whose fruit is a trap of the moment Inertia, a state of walking in place (Main, 2012).

The use of social media also affects the turbulent conditions of the political year (Barokah & Hertanto, 2020). Research (Mustapha et al. 2020; Sharma and Ghose 2020; Meng 2022). Finding that Social Media Affects Vote Gain (Ridge-Newman, 2020). Social media becomes a medium of debate influencers Social media that consumes energy and drags society into polarization, segmentation, and segregation as happened in India, Spain (González-neira and Conde-vázquez 2020; Mustapha et al. 2020)Nigeria (Mustapha & Omar, 2020), and Morocco (Acharoui et al. 2020), as well as Singapore (Zhi et al. 2020). Reflecting on the experience of other countries, according to conflict theory, the sequence of the 2024 Indonesian election process has the potential to result in conflict escalation (Fadilah 2021). Escalation occurs because interested parties will take advantage of existing issues to attract the interest of voters (Kurnia & Astuti, 2017; Mustapha & Omar, 2020; Warren, 2020), and allegedly one of the issues that will pass on social media is the issue of populism in identity politics (Iannone 2022).

This phenomenon raises questions about the existence of issues that will pass on social media (Firmanto 2021a; 2021b). Will those issues lead society to the turbulence of the political year? What are the actions of the community in response to hoaxes and fake news? Is there hope for peace and harmony? (Adon & Firmanto, 2022; Letsoin et al., 2021; Taroreh et al., 2021).

It is assumed that everyone knows the universal values of humanity, both from religious sources (Firmanto 2017) and sources of Local Culture (Handoko 2020; Noble 2020; Preston, Ritter, and Ivan Hernandez 2010). Such recognition will give rise to the hope of living in harmony (Arshad et al., 2020; Epitropaki & Martin, 2005; Lord et al., 2016). Research results (Hendricks et al. 2022; Ghosh and Martcheva 2021; Aydin Sünbül 2021; De Groot and Steg 2009) show that social consciousness is effective and experienced. The researcher assumes that in the Indonesian context, the experience of religiosity in togetherness with the community will affect the feeling of peace, calm, harmony, and solidarity in the community from a theoretical perspective of bridging and bonding (Lee, 2019; Mittal & Dorfman, 2012; Murray & Petts, 2020; Saroglou et al., 2020; Sulphrey & Salim, 2021). This study proposes the statement that faith-inspired interrelational citizenship will be the catalyst for its realization of Justice, Peace, and Social Integration Based on Local and Religious Values (Zaenuddin et al. 2022a).

Research (Gannon and Roberts 2018; Li et al. 2022) indicates that reinforcement Social capital is one of the strategies to get out of moments of inertia. The social capital that is the material object of this study is Civil Society in the form of community-based educational institutions (Rasdi 2020; Zhang et al. 2019; Hafenbrack et al. 2019). Empirically, the experience of community-based educational institutions in Greece is one of the factors in the country's release from turbulent situations as a result of the political process (Apostolopoulos, Newbery, and Gkartzios 2018). Based on this experience, the data unit of civil society in the form of Community-based educational institutions in Indonesia are believed to have the ability to receive, manage, and assess as well as respond to social media information to survive the turbulence of the political year (Eunuch et al., 2021; Kharlie, 2023; Sukamto & Parulian, 2020).

2. Theoretical Foundation

The concept of faith-inspired interrelational citizenship (FIC) in a harmonious and peaceful society is a synthesis of Social Exchange theory, Social Capital theory, and Prosocial Behavior theory (Agudelo & Cortes-Gómez, 2021; Untea, 2018; Xia et al., 2021; Zaenuddin et al., 2022).

Social Exchange theory states that the continuity of the relationship of two or more individuals depends on the exchange that occurs. Each individual voluntarily enters and stays in social relationships only as long as those relationships are satisfactory (Ahmadi-Gh and Bello-Pintado 2022; Kim and Qu 2020; Lord, Gatti, and Chui 2016).

Next Social Capital Theory states that society is an organism that can declare its existence (Cret, 2021; Gannon & Roberts, 2018; Mikovi et al., 2020; Murray & Petts, 2020). Social capital has aspects of: 1) reciprocal trust, that is, to think and act positively towards others; 2) solidarity, i.e. social solidarity; 3) tolerance, i.e. willingness to sacrifice in bearing differences of opinion, creed, or habit; 4) equality, i.e. Acknowledgment of correspondence and break even with getting to the assets of life (such as social, social, and political economy); 5) social systems and organizations (affiliations), i.e., gatherings or media of social relations; and 6) interest (Civic Engagement) and participation, that's, the support of an individual in his community and participation to attain the common great (Banusu & Firmanto, 2020).

Prosocial Behavior theory explains the existence of voluntary actions of an individual or a group intended to help or benefit another individual or group of individuals (Fiorito et al., 2021; Hilbig et al., 2014; Piatak & Holt, 2019; Silke et al., 2018; Tsang et al., 2021). Faith-inspired Correlational Citizenship (FIC) is a willingness to meet, work together, and share information to realize a new value that is aspired to together is encouraged by the main religious values (Agudelo & Cortes-Gómez, 2021; Batson et al., 1989; Fiorito et al., 2021; Preston et al., 2010; Saroglou, 2012; Tsang et al., 2021; Xia et al., 2021). FIC Concept is a relationship model that describes the concept of bridging and bonding in a democratic society that is imagined to produce a feeling of comfort (affective aspect) that reinforces organizational commitment in an individual (Pfattheicher, Nielsen, and Thielmann 2022; Preston, Ritter, and Ivan

Hernandez 2010; Tsang, Al-Kire, and Ratchford 2021). Aspects faith-inspired became a distinctive aspect of the FIC concept because the maturity of religiosity resulted in peace, justice, and solidarity.

Table 1. State of the art of Faith-Inspired Interrelational Citizenship (FIC)

Researchers	Dimension	Definition	Indicators
(Gallie et al. 2017; Underwood 2011; Manila 2018; Kim and Qu 2020)	Feelings of gratitude	A response to life experiences that results in peace of heart and peace of mind.	Take time for reflection. Be grateful for life. Thanks to others for positive influences.
(Funk, 2021; Khan et al., 2019; Sumbulah, 2015; Thomas & Rowland, 2014; Underwood, 2011)	Awareness of the mission calls for humanity	The belief is that human sociality serves to reduce suffering and build life together.	Altruistic compassion Sharing possessions (money/time/energy/thoughts) Volunteerism in kindness Working together for a better quality of life
(Jena 2014; Huber and Huber 2012; Lambert et al. 2013; Routledge et al. 2011; Steger et al. 2008; FioRito, Routledge, and Jackson 2021)	Meaningful life	The belief that life itself is meaningful so that people are willing to construct their lives based on universal values.	Be open to new situations Have a purpose in life Balancing social and personal life Have an expression that values life
(Agudelo & Cortes-Gómez, 2021; Ganzevoort & Roeland, 2014; Neugebauer et al., 2020)	Spiritual engagement	Involvement in spiritual beliefs and practices.	Ponder topics such as pain, suffering, or death. Improve the quality of relationships with others. Show empathy and generosity.
(Arshad et al., 2020; Baldassarri & Abascal, 2020; FioRito et al., 2021; Piatak & Holt, 2019; Preston et al., 2010; Saroglou, 2012; Silke et al., 2018; Tsang et al., 2021)	Prosocial engagement	Social behavior is contributive to other individuals or groups.	reciprocal trust solidarity Tolerance gender equality Same access Social Network Civic Engagement Positive attitude towards plurality

3. Hypotheses Development

H1: There is a significant relationship between awareness of mission calls for humanity and faith-inspired inter-relational citizenship.

Mission awareness calls for humanity and refers to the recognition and understanding of significant social or global challenges that require collective action. This concept suggests that when people are aware of an urgent mission, such as tackling climate change or promoting equality, they are more inclined to collective action. By recognizing the urgency of this mission, individuals and groups can hypothesize potential causes, impacts, and interventions, thus encouraging proactive problem-solving. This awareness-driven hypothesis construction aligns with a shared commitment to creating innovative solutions. Positive impact on the world, encouraging thoughtful exploration and experimentation to drive meaningful change (Gallie et al. 2017; Manila 2018; Kim and Qu 2020; Underwood 2011).

Faith-inspired inter-relational citizenship includes the idea of individuals leveraging their spiritual beliefs to foster positive relationships among diverse communities. This concept suggests that faith-based principles can inspire individuals to engage in active citizenship, transcending cultural and religious boundaries. By investigating this phenomenon, hypotheses can explore how beliefs-driven values influence attitudes toward inclusivity, cooperation, and social responsibility. In addition, research can investigate whether faith-based interactions improve intergroup relationships and enhance a sense of shared humanity. By examining the relationship between faith, inter-relational dynamics, and citizenship, hypotheses can contribute to a deeper understanding of how spirituality shapes community engagement.

H2: There is a significant relationship between awareness of mission calls for humanity and local and religious values.

Local and religious values as the cornerstone of humanitarian mission vocation awareness are concerned with the influence of community-specific and spiritual beliefs in fostering awareness of critical global challenges. The concept argues that people's attachment to local and religious values can increase their recognition of urgent missions such as environmental conservation or social justice. Building research hypotheses in this context can explore how these values shape individuals' perceptions of global issues, their willingness to engage in collective action, and the effectiveness of awareness campaigns rooted in cultural and religious narratives. Investigating these relationships provides insight into harnessing local beliefs to foster broader awareness and impactful change (Gallie et al. 2017; Manila 2018; Kim and Qu 2020; Underwood 2011).

H3: There is a significant relationship between meaningful life and faith-inspired inter-relational citizenship.

Meaningful life refers to the sense of purpose, fulfillment, and satisfaction an individual experiences in their existence. It is often associated with a deeper understanding of one's values, and goals, and a sense of connection to something greater than oneself (Steger, Frazier, Oishi, & Kaler, 2006). Research has shown People with a better sense of meaning in life tend to show more noteworthy mental well-being, upgraded versatility, and expanded pro-social behaviors (Martela & Steger, 2016). Faith-inspired interrelational citizenship alludes to the dynamic engagement and interest of people from assorted confidence foundations in cultivating positive connections and participation inside a community. It includes advancing understanding, sympathy, and collaborative endeavors based on shared values and convictions motivated by confidence (Berkowitz & Grych, 1998). This citizenship shape is vital in building social cohesion, improving common regard, and bridging isolation between devout and social bunches (Djupe & Gilbert, 2003).

The framework proposes that a meaningful life can catalyze individuals to engage in faith-inspired interrelational citizenship. When individuals find purpose and significance in their lives, they are more likely to develop a broader perspective that transcends personal interests. This expanded worldview often leads to more vital empathy and compassion towards others, regardless of their religious or cultural backgrounds (Emmons, 2003). Studies have indicated that individuals with a higher sense of meaning in life are more inclined to engage in pro-social behaviors and display more significant concern for the well-being of others (van Tongeren, Green, Davis, Hook, & Hulse, 2016). Furthermore, research has shown that faith-inspired practices can foster a sense of interconnectedness and common humanity among individuals from different religious backgrounds (Ritter, Preston, & Hernandez, 2016).

H4: There is a significant relationship between meaningful life and local and religious values.

Significant life alludes to the subjective discernment of people that their lives are noteworthy, deliberate, and satisfying. It includes a sense of coherence, heading, and understanding of one's values, objectives, and reason in life (Steger, Frazier, Oishi, & Kaler, 2006). Individuals with a better sense of meaning in life tend to involve more prominent mental well-being and general life fulfillment (Steger, Kashdan, & Oishi, 2008). Neighborhood values include the social and societal standards, conventions, and convictions predominant inside a particular community or topographical locale. These values frequently shape the personality and hones of the community individuals and impact their states of mind

and behaviors (Triandis, 1995). Devout values, conversely, are the moral standards, ethical rules, and otherworldly convictions determined from devout lessons and teachings (Slope & Pargament, 2003). These values direct the conduct and choices of disciples and play a central part in their daily lives.

The system proposes a forbidden relationship between an individual's sense of significant life and adherence to nearby and devout values. Nearby and holy values give people an ethical compass and a system for understanding their reason and part inside their community and otherworldly setting (Wong, Reker, & Gesser, 1993). In turn, a vital life can strengthen the significance of these values and encourage their integration into one's way of life. Various things have investigated the association between devout values and the discernment of significant life. Inquire has found that people who emphasize their righteous convictions and hones report a more noteworthy sense of meaning and reason (Krause, 2003; Lambert, Stillman, Baumeister, Fincham, Hicks, Graham, 2010). Adherence to nearby values and social conventions has been related to a more grounded sense of personality, social having a place, and life fulfillment (Cohen, 2009; Uskul & Over, 2016).

Besides, it has appeared that people who coordinate their devout values into their everyday lives involve the next level of mental well-being and flexibility, contributing to a more noteworthy recognition of life's importance (Slope & Pargament, 2003; Stop, 2010).

H5: There is a significant relationship between spiritual engagement and faith-inspired inter-relational citizenship.

Spiritual Engagement raised from Faith-Inspired Inter-Relational Citizenship" encapsulates the idea of individuals deriving heightened spiritual involvement through their commitment to cross-cultural, faith-driven citizenship. This concept suggests that engaging in positive interactions across religious boundaries can deepen one's spiritual connection and sense of purpose (Agudelo & Cortes-Gómez, 2021; Ganzevoort & Roeland, 2014; Neugebauer et al., 2020). Constructing research hypotheses around this concept could explore how faith-based inter-relational interactions influence individuals' spiritual experiences, personal growth, and community contributions. Further investigation might delve into whether these experiences lead to enhanced well-being and a more profound sense of interconnectedness. By studying the relationship between faith, inter-relational citizenship, and spiritual engagement, hypotheses can shed light on the complex interplay of these factors.

H6: There is a significant relationship between spiritual engagement and local and religious values.

Spiritual Engagement based on Local and Religious Values entails individuals cultivating a deeper spiritual connection by aligning their beliefs with local customs and religious principles. This concept proposes that integrating cultural and religious values can enhance spiritual experiences and personal growth. Research hypotheses within this context might explore how these values contribute to individuals' sense of purpose, well-being, and community involvement. Additionally, investigations could examine whether spiritual engagement rooted in local and religious contexts leads to greater empathy, social responsibility, and cross-cultural understanding. By probing the interplay between spirituality, values, and engagement, hypotheses can offer insights into fostering meaningful connections and enriching lives (Agudelo & Cortes-Gómez, 2021; Ganzevoort & Roeland, 2014; Neugebauer et al., 2020).

H7: There is a significant relationship between prosocial engagement and faith-inspired inter-relational citizenship.

The connection between prosocial engagement and faith-inspired inter-relational citizenship explores how individuals driven by faith-based inter-relational principles are more likely to exhibit prosocial behaviors. This concept suggests that religious values encouraging inclusive interactions across diverse groups can inspire actions benefiting others and the community. Constructing research hypotheses around this concept could investigate how such citizenship fosters empathy, cooperation, and altruism (Arshad et al., 2020; Baldassarri & Abascal, 2020; Fiorito et al., 2021; Piatak & Holt, 2019; Preston et al., 2010; Saroglou, 2012; Silke et al., 2018; Tsang et al., 2021). Additionally, hypotheses might explore whether the motivation drawn from faith-driven inter-relational principles leads to increased volunteerism, charitable activities, and social support networks. By examining the correlation between faith-

inspired citizenship and prosocial engagement, research can unveil pathways to harnessing spirituality for societal betterment.

H8: There is a significant relationship between prosocial engagement and local and religious values.

The connection between prosocial engagement and local and religious values centers on how individuals influenced by their cultural and religious beliefs tend to exhibit higher levels of prosocial behavior. This concept suggests that values rooted in local traditions and spiritual teachings can inspire actions that benefit others and the community (Arshad et al., 2020; Baldassarri & Abascal, 2020; Fiorito et al., 2021; Piatak & Holt, 2019; Preston et al., 2010; Saroglou, 2012; Silke et al., 2018; Tsang et al., 2021). Constructing research hypotheses around this concept involves exploring how these values contribute to empathy, cooperation, and altruism. Additionally, hypotheses could delve into whether individuals guided by local and religious values are more likely to engage in volunteering, charitable acts, and fostering social bonds. By examining this correlation, research can uncover ways to leverage cultural and religious values to promote prosocial engagement.

H9: There is a significant relationship between faith-inspired inter-relational citizenship and local and religious values.

The connection between Faith-Inspired Inter-Relational Citizenship and Local and Religious Values explores how individuals who practice faith-driven inter-relational citizenship often draw upon their local cultural and religious values to guide their actions. This concept suggests that embracing diverse faith-based principles can enhance cross-cultural understanding, empathy, and community engagement. Constructing research hypotheses within this framework involves investigating how these values shape individuals' approaches to intergroup interactions, cooperation, and societal contributions. Additionally, hypotheses might explore whether faith-inspired inter-relational citizenship fosters a sense of shared humanity and promotes social harmony by bridging differences. By studying this connection, research can illuminate ways to harmonize faith, values, and citizenship for a more inclusive and interconnected society (Arshad et al., 2020; Baldassarri & Abascal, 2020; Fiorito et al., 2021; Piatak & Holt, 2019; Preston et al., 2010; Saroglou, 2012; Silke et al., 2018; Tsang et al., 2021).

4. Research Method

This study uses mixed methods. Design sequential explanatory models on qualitative approaches to find patterns and test hypotheses. Data collection techniques using questionnaires, in-depth interviews, documentation, and triangulation, with research instruments: tests, questionnaires, standard instruments, notebooks, tape recorder, camera, and handycam. Hypothesis testing is proven by the support of qualitative data and quantitative data. The research object is civil society in the form of community-based educational institutions in the form of formal educational institutions in East Java, namely the Karmel Foundation (Catholic religious base), the Aletheia Indonesia Christian Foundation (Christian religious base), Jatim LP Ma'arif NU (Islamic religious base), the Pasraman Ganesha Parwati Foundation (Hindu religious base) and the Buddhist Education Foundation (Buddhist religious base). The units of observation are foundation administrators, teachers, and educational staff.

The sample number is 234 respondents, this number already meets the SEM processing requirements (Hair et al. 2014). SEM-PLS to assess outer and inner structural models and test hypotheses. Outer assessment to evaluate validity, consisting of average variance extracted test, loading factor, and Fornell lesser criteria. Reliability evaluation through composites. Fit is assessed on each path in the model by evaluating R2 measurements, predictive relevance Q2, and significance of path coefficients, f2, and q2 evaluations (Ghozali 2011). Qualitative testing tools are instruments for understanding, analyzing, and interpreting data that is descriptive and complex.

Table 2. Instruments

Variable	Instruments	References
Independent	A New Scale for Measuring Adults' Prosocialness	(Caprara et al. 2005)

	Religious Identity, Between-Group Effects and Pro-social Behavior: Evidence from A Field Experiment in China	(Xia et al. 2021)
	Religiosity and the Motivation for Social Affiliation	(Van Cappellen et al. 2017)
	Meaningful life	
	Spiritual engagement	
Dependent	Assessing Attitudes towards Mutual Acculturation in Multicultural Schools: Conceptualization and Validation of a Four-Dimensional Mutual Acculturation Attitudes Scale	(Sidler et al. 2021)
	Being Religious and Being Altruistic: A Study of College Service Volunteers	(Bernt 1989)
Intervening	Faith-inspired Interrelational Citizenship (FIC) scales	(Zaenuddin et al. 2022b; Huber and Huber 2012; McDaniel 2015; Khozin 2013)

5. Result of Quantitative Analysis

Outer Model Evaluation

There are 2 (two) second-order variables, namely: Faith-inspired inter-relational citizenship and local and religious values, and 4 (four) first-order variables. The results of the evaluation of validity and reliability for each construct in the measurement model are shown in Table 3 which summarizes the criteria of loading factor, Cronbach's Alpha, AVE, and composite reliability for each construct in this study.

Table 3: Validity and reliability criteria for each construct

Variable	Dimension and indicator	Sym- bol	Load- ing Fac- tor ^{*)}	Cronbach's Alpha ^{**)}	Composite Reliability ^{***)}	AVE ^{****)}	
Faith-in- spired inter- relational citizenship	1. Religiosity			0,891	0,925	0,754	
	Confidence level	CL	0,848				
	Religious practice	RP	0,874				
	Participation in religious activities	PR	0,906				
	Understanding of religious values	URV	0,844				
	2. Citizenship			0,921	0,941	0,761	
	Political participation	PP	0,890				
	Legal compliance	LC	0,858				
	Social participation	SP	0,857				
	Political awareness	PA	0,934				
	3. Interfaith cooperation	Interreligious dialogue	ID	0,833	0,897	0,917	0,733
		Collaboration in social projects	CSR	0,869			
		Interfaith education and awareness	IEA	0,868			
		Joint activities in religious events	JAR	0,854			
Awareness of mission	Understanding of humanity's challenges	UGC	0,838	0,879	0,916	0,732	

calls for humanity:	Awareness of personal involvement	API	0,850			
	Knowledge of humanitarian organizations and initiatives	KHO	0,871			
	Motivation for humanitarian action	MHA	0,863			
Meaningful life	Social connection	SC	0,874	0,866	0,909	0,714
	Achievements and contributions	AC	0,845			
	Meaning and value	MV	0,856			
	Personal growth	PG	0,874			
Spiritual engagement	Religious practices	URP	0,828	0,827	0,885	0,658
	The search for meaning	SM	0,828			
	Religious community	RC	0,834			
	Ethics and values	EV	0,787			
Prosocial engagement	Religious practices	URP	0,828	0,877	0,916	0,731
	The search for meaning and understanding	SMU	0,861			
	Connection with nature or transcendental power	CNT	0,839			
	Application of spiritual values and ethics	ASV	0,890			
Local and religious values	1. Justice			0,908	0,923	0,523
	Equality and fair treatment	EVT	0,880			
	Participation and equal opportunity	PEO	0,870			
	Transparency and accountability	TA	0,915			
	Law and human rights	AHR	0,886			
	2. Peace			0,898	0,929	0,766
	Nonviolence	NV	0,850			
	Justice and equality	JE	0,880			
	Dialogue and diplomacy	DD	0,882			
	Sustainable development	SD	0,888			
	3. Social integration			0,873	0,913	0,724
	Community Membership	CM	0,856			
	Social network	SN	0,844			
	Political and civil participation	PCP	0,863			
Inclusion and acceptance	IA	0,841				

*)stacking calculate ought to be more than 0.7; **)Cronbach's Alpha ought to be more than 0.7; ***). Composite unwavering quality ought to be more than 0.7; ****)AVE ought to be more than 0.5

Based on Figure 1 and Table 3, it can be seen that more than 70% of the fluctuation of each marker can be clarified by the factors of this ponder. In this way, in general, each idle variable can explain the information change. The composite unwavering quality esteem of the five inactive factors and their measurements features a composite unwavering quality esteem over 0.6. That is, the built-up pointers can degree each fixed variable well, or it can be said that the five estimation models are solid. The tall relationship between indicators that make up the development also appears to have great concurrent legitimacy esteem. The AVE esteem of the five inactive factors features affection over the slightest basis, which is 0.5, so the degree of concurrent legitimacy is excellent or can be said to meet the focalized

legitimacy criteria. The other measure is discriminant legitimacy, by comparing the relationship between builds with the roots of AVE or Fornell-Lacker Criteria in Table 4.

Table 4: Fornell-Lacker Criteria

Path	Awareness of the mission calls for humanity	Faith-inspired inter-relational citizenship	Local and religious values	Meaningful life	Prosocial engagement	Spiritual engagement
Awareness of the mission calls for humanity	0,856					
Faith-inspired inter-relational citizenship	0,484	0,698				
Local and religious values	0,575	0,671	0,723			
Meaningful life	0,513	0,640	0,739	0,845		
Prosocial engagement	0,461	0,596	0,718	0,610	0,855	
Spiritual engagement	0,465	0,609	0,814	0,694	0,685	0,811

***Fornell-Lacker Criteria ought to be more than the relationship esteem of that develop to. The values run from 1, where the next affection shows a higher unwavering quality level. In exploratory inquiries, values of composite reliability/Cronbach alpha between 0.60 to 0.70 are worthy, whereas in more advanced arrange the esteem got to be higher than 0.70.

1 Based on Table 4 above, all constructs meet the Fornell Lacker criteria, indicating that all constructs are valid and reliable.

Inner Model Assessment

Test the possibility of the demonstration utilizing the r-square esteem. The result of the r-square esteem investigation for Faith-Inspired Inter-Relational Citizenship was 0.506. The figure clarifies that the inconstancy of endogenous factors can be defined by the changeability of exogenous factors of 50.6%, whereas the r-square esteem for Neighborhood and Devout Values is 0.773. The figure clarifies that the inconsistency of endogenous factors can be defined by the change of exogenous factors of 77.3%. In expansion to r-square, an examination was carried out on the impact of exogenous factors on known endogenous factors based on the esteem of impact measure f-square and q-square displayed in Figure 1 and Table 5 below.

Table 5: r-square, f-square, and q-square

Construct	r-square*)	f-square**)	Q-square ***)
Faith-Inspired Inter-Relational Citizenship	0,506	0,532	0,234
Local and Religious Values	0,773	0,626	0,396

2 *)path with r-square less than 0.5 is considered weak predictive accuracy; **) ^ path with an f-square above 0.35 is considered large; *) ^ **)path q-square of more than 0.25 is considered medium predictive relevance

2 The faith-inspired inter-relational citizenship variable (r-square = 0.506) had a lower contribution than local and religious values (r-square = 0.773), while the q-square variable local and religious values (0.396) had higher predictive validity than the faith-inspired inter-relational citizenship variable (q-square = 0.396). Thus, it can be concluded that local and religious values have a higher contribution in explaining variations in faith-inspired inter-relational citizenship based on higher r-square values. In addition, these two variables have relatively good predictive validity based on positive q-square values.

Table 5 data shows that kinship has a significant impact in shaping the social structure and cultural values of Indonesian society. It creates a strong sense of attachment between family members and provides the basis for widespread social solidarity in everyday life. Kinship strength, often referred to as family strength or family relationships, has an important role in Indonesian society. Indonesia is a country with a culture that attaches great importance to family values, intergenerational solidarity, and emotional attachment between family members.

Hypothesis Testing

The results of the path coefficient (path beta) and t-statistic values obtained through the bootstrap-
 ping process with a sample number of 234 are shown in Figure 1 and Table 6 as follows.

Table 6: Path beta, t-value, and P-value

Path	Path beta	t-value	P-value	Result
Awareness of mission calls for humanity → faith-inspired inter-relational citizenship	0,141	2,403	0,017	Accepted
Awareness of the mission calls for humanity → local and religious values	0,143	2,972	0,003	Accepted
Meaningful life → faith-inspired inter-relational citizenship	0,312	4,148	0,000	Accepted
Meaningful life → local and religious values	0,187	2,927	0,004	Accepted
Prosocial engagement → faith-inspired inter-relational citizenship	0,220	3,415	0,001	Accepted
Prosocial engagement → local and religious values	0,177	2,526	0,012	Accepted
Spiritual engagement → faith-inspired inter-relational citizenship	0,176	2,396	0,017	Accepted
Spiritual engagement → local and religious values	0,424	6,909	0,000	Accepted
Faith-inspired inter-relational citizenship → local and religious values	0,119	2,334	0,020	Accepted

Table 6 displays the influence of Awareness of Mission Calls for Humanity on faith-inspired inter-relational citizenship (0.141 with a p-value of 0.017) and local and religious values (0.143 with a p-value of 0.003). It also demonstrates the influence of Meaningful Life on faith-inspired interrelational citizenship (0.312 with a p-value of 0.000) and local and religious values (0.187 with a p-value of 0.004). Furthermore, it showcases the impact of Prosocial Engagement on faith-inspired inter-relational citizenship (0.220 with a p-value of 0.005) and local and religious values (0.177 with a p-value of 0.012). The influence of Spiritual Engagement on faith-inspired inter-relational citizenship is indicated as 0.176 with a p-value of 0.017 and on local and religious values as 0.424 with a p-value of 0.000. Additionally, it illustrates the influence of faith-inspired inter-relational citizenship on local and religious values as 0.119 with a p-value of 0.020. According to (J. F. Hair et al., 2019), if $p < 0.05$, the alternative hypothesis (H_a) is accepted. This implies that all nine proposed hypotheses can be considered to have a significant effect..

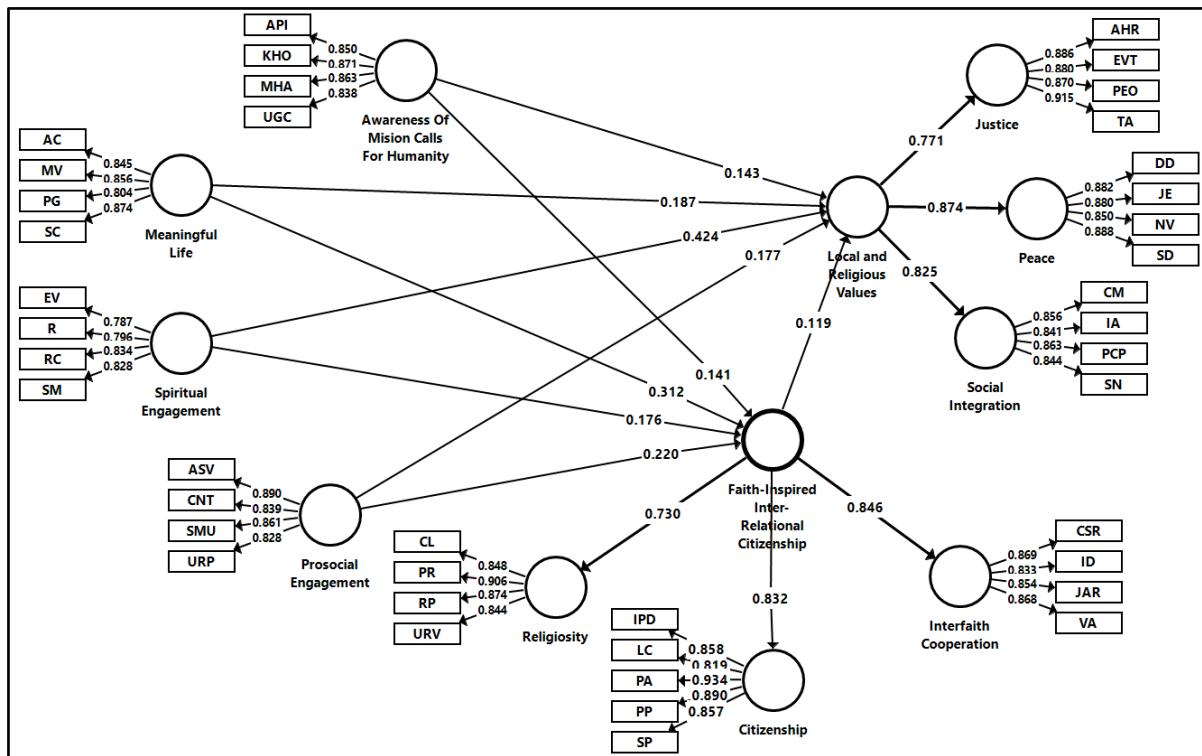

Figure 1: Path diagram and loading factor values

Discussion for Quantitative Result:

These findings reveal that awareness of humanitarian mission vocations, meaningful living, prosocial engagement, and spiritual involvement exerts a positive and significant influence on faith-inspired inter-relational citizenship and local and religious values. Furthermore, faith-inspired inter-relational citizenship positively and significantly impacts local and spiritual values. These results underscore the profound dimension within the relationship between Mission Awareness Calling for Humanity and Faith-Inspired Inter-Relational Citizenship (Arshad et al., 2020; Baldassarri & Abascal, 2020). Educators acknowledge that fostering awareness of global challenges among students can be facilitated by instilling faith-inspired inter-relational values. This approach seamlessly integrates spiritual principles, enhancing empathy and cooperation across diverse cultures. Educators discern the potential in religious teachings to fortify students' dedication to effecting positive societal change. However, concerns persist regarding potential exclusivity and value conflicts stemming from these efforts. (FioRito et al., 2021; Piatak & Holt, 2019; Preston et al., 2010; Saroglou, 2012; Silke et al., 2018; Tsang et al., 2021).

6. Results of Qualitative Analysis

This report delves into the rich insights educators from diverse educational backgrounds provide regarding the intricate relationships between leading a meaningful life and embracing faith-based inter-relational citizenship. The primary objective of this exploration is to gain a deeper understanding of how educators perceive the role of religious principles in fostering cross-community cooperation. To achieve this, semi-structured interviews were conducted with the participants.

Meaningful Life

Participants A (representing Islam), B (Christianity), and C (Buddhism) offer profound perspectives on the concept of a meaningful life, as viewed through the lenses of their respective faiths and personal values. Islamic teachings emphasize the importance of service and purpose; Christianity integrates faith into action, while Buddhism places a strong emphasis on introspection. Despite these distinct approaches, a common thread emerges – a shared human yearning for purpose, values, and self-

awareness. This exploration underscores a universal desire to transcend religious boundaries and prompts questions about how these perspectives influence individuals' responses to life's challenges and their contributions to society.

Awareness of Mission Calls for Humanity

Perspectives from Participants A (Islam), B (Christianity), and C (Buddhism) delve into the significance of nurturing relationships grounded in human values and empathy, albeit through different religious prisms. Islam advocates global brotherhood and underscores the worth of heart through the concept of a humanitarian mission. Christianity emphasizes the call to create harmony and togetherness among people, reflected in Christian values such as love and inclusivity, where faith-driven actions contribute to a mutually supportive society. On the other hand, Buddhism places great importance on consciousness in forming connections between individuals, with compassion as a driving force for actively improving social and humanitarian conditions.

Prosocial Engagement

Perspectives of Participants A (Islam), B (Christianity), and C (Buddhism) delve into the significance of engaging in positive actions that promote social welfare, albeit through varying religious lenses. Islam highlights the importance of proactive social engagement in aiding others and enhancing societal conditions, aligning with Islamic teachings on 'Alms' and service to create a positive community impact. In bold actions, Christianity underscores the significance of love and concern for others' needs, reflecting Christian values such as "loving your neighbor," which advocate selfless giving. Buddhism emphasizes the role of empathy and conscious concern in pro-social actions, consistent with the principle of compassion, encouraging individuals to prioritize the welfare of others and contribute to the common good.

Spiritual Engagement

Participants A (Islam), B (Christianity), and C (Buddhism) investigate the noteworthiness of otherworldly engagement as an implication to achieve peace, reflection, and individual development, with significant suggestions for one's relationship with God or the universe. Islam advances otherworldly associations to draw closer to God and discover life's meaning, with exercises like supplication, dhikr, and tafakur seen as roads for inward peace and fortifying the Creator's relationship. Christianity underscores otherworldly engagement as a profound association with God through supplication, reflection, and reflection on God's Word, cultivating closeness to God and phenomenal development. Buddhism highlights supernatural association as an exertion toward illumination and self-awareness, with contemplation and profound reflection supporting an understanding of the nature of enduring and accomplishing internal peace.

Faith-Inspired Relational Citizenship

Participants A (Islam), B (Christianity), and C (Buddhism) offer viewpoints on faith-inspired inter-relational citizenship, emphasizing the part of otherworldly values in manufacturing a concordant society. Speaking to Islam, Member A emphasizes all-inclusive brotherhood and sympathy over social contrasts. Member B, the Christian teacher, underscores the significance of cherishing and inclusivity inside a Christian system. Member C, speaking to Buddhism, sees inter-relational citizenship as an implication to address societal issues through kindness and connectedness. This point of view calls for appreciating humanity's solidarity and the greatness of contrasts, possibly forming a comprehensive and collaborative vision for society. Assist investigation of how confidence rouses beneficial societal activities remains an interesting road inside an instructive setting.

Local and Religious Values

Participants A (Islam), B (Christianity), and C (Buddhism) express their points of view on the part of neighborhood and devout values in forming individuals' morals, ethics, and societal well-being. Islam underscores the centrality of nearby and holy values in developing solid character and ethics, with values like trustworthiness, support, and sympathy shaping the bedrock of the standard of living. Christianity highlights the keenness of neighborhood and devout values in forming morals and behavior, with matters such as adore, kindness, and obligation toward others serving as the establishment for tending to life's challenges. Buddhism underscores the part of neighborhood and devout values in

cultivating inward peace and well-being, with values like resilience, persistence, and regard for all creatures essential to accomplishing peace of intellect.

Discussion for Qualitative Result

These compelling findings show that awareness of humanitarian mission vocations, meaningful living, prosocial engagement, and spiritual involvement will positively influence faith-inspired inter-relational citizenship and local and religious values. Furthermore, it's important to note that faith-inspired inter-relational citizenship significantly and positively impacts local and spiritual values. These discoveries unveil the profound dimensions within the relationship between Mission Awareness Calling for Humanity and Faith-Inspired Inter-Relational Citizenship. (Zaenuddin et al. 2022b; Huber and Huber 2012; McDaniel 2015; Khozin 2013).

Educators wholeheartedly recognize the potential of instilling faith-inspired inter-relational values in students. They understand this approach integrates spiritual principles, fostering empathy and cooperation across diverse cultures. Moreover, educators see the power of religious teachings to bolster students' commitment to effecting positive societal change. However, they remain vigilant about exclusivity or clashes among belief systems. Striking a balance between these aspects, educators appreciate the synergy between mission awareness and faith-driven inter-relational citizenship, which serves as a platform for meaningful dialogue and collaborative action, ultimately shaping responsible global citizens (McDaniel, 2015; Zaenuddin et al., 2022).

The correlation between Mission Awareness, Calling for Humanity, and Local and Religious Values is multifaceted. Educators acknowledge that integrating local and religious values can enrich students' understanding of global challenges, grounding them in cultural heritage. Nevertheless, concerns about potential bias or exclusion stemming from diverse value systems have arisen. Educators emphasize the necessity for an inclusive approach that respects differences in faith while fostering collective responsibility. These connections offer a unique avenue to engage students, aligning global missions with personal values. By promoting critical thinking and respectful dialogue, educators envision a harmonious equilibrium between awareness, deals, and active participation in addressing human needs (Zaenuddin et al. 2022b; Huber and Huber 2012; McDaniel 2015; Khozin 2013).

The relationship between leading a Meaningful Life and Faith-Inspired Inter-Relational Citizenship offers profound insights. Integrating faith-based inter-relational principles enhances students' pursuit of a purposeful life, fostering empathy, cultural understanding, and a sense of belonging. However, educators remain attentive to concerns regarding potential exclusivity or dogmatism. They underscore the importance of encouraging critical thinking and open-mindedness while nurturing students' spiritual growth. These connections provide a framework for students to channel their beliefs into positive interactions, contribute to meaningful lives through collective engagement, transcend boundaries, and foster a broader sense of purpose and satisfaction.

Moreover, serious thought is encouraged by the nexus of faith-inspired inter-relational citizenship and prosocial engagement. Teachers recognize that inter-relational values based on faith frequently cause children to act more prosocially, promoting empathy, cooperation, and a sense of duty toward others. However, worries about conflicts resulting from different religious systems have been voiced. Instructors emphasize the importance of inclusive interpretations that uphold individual beliefs while fostering togetherness. These connections light how students can incorporate their values into deeds of virtue, create a culture that positively affects society by embracing diversity, lead by example, and provide an example of kindness.

The connection between prosocial engagement and local and religious values offers a critical viewpoint. Educators acknowledge that local and religious values frequently encourage students to exhibit heightened prosocial behavior, nurturing compassion, community involvement, and ethical responsibility. However, concerns have been raised about potential clashes among different value systems. Educators advocate for inclusive teaching that celebrates diversity while fostering unity. These connections offer a platform for students to align their personal beliefs with acts of kindness, thereby contributing to a more compassionate society. Educators underscore the importance of fostering empathy and promoting respectful dialogue, enabling students to embody shared values while

embracing their individual religious beliefs (Zaenuddin et al. 2022b; Huber and Huber 2012; McDaniel 2015; Khozin 2013).

Views on the interaction between Spiritual Engagement and Faith-Inspired Inter-Relational Civic Engagement reveal profound reflection. Educators recognize that faith-driven interrelational values often lead to deeper spiritual connections, fostering empathy, understanding, and a sense of shared humanity. Nevertheless, concerns about the potential for exclusivity or bias associated with diverse beliefs have been raised. Teachers advocate for cultivating open-mindedness and respectful discourse while nurturing students' spiritual growth. These relationships highlight avenues for students to channel their ideas into positive interactions, contribute to a meaningful existence by transcending boundaries, embracing diversity, and collectively cultivating a sense of spiritual fulfillment through compassionate engagement.

7. Conclusion

This research passionately reveals that awareness of humanitarian mission vocations, meaningful living, prosocial engagement, and spiritual involvement wielded a remarkably positive and significant influence on faith-inspired inter-relational citizenship and local and religious values. These groundbreaking findings illuminated the profound and intricate dimensions of the relationships among these crucial elements. Educators enthusiastically embraced the immense value of infusing faith-inspired inter-relational principles into education, recognizing the potential to elevate students' awareness of global challenges, nurture empathy, and foster cross-cultural cooperation. Nonetheless, they astutely flagged potential challenges, including the risk of exclusivity and conflicts of values in these transformative endeavors.

Yet, it must be acknowledged that this study grappled with several limitations. Primarily, it focused exclusively on the perspectives of educator managers, inadvertently neglecting the invaluable insights of other education practitioners, potentially constraining the breadth of our understanding. Furthermore, the bulk of findings relied heavily on educators' viewpoints, with no quantification of real-world student behavior. Lastly, due to the study's confined scope to a specific locale, the generalizability of its findings to broader contexts remained somewhat restricted. To rectify these shortcomings, future research endeavors should delve deeper into the tangible impact of integrating religiously inspired inter-relational values into education. This would involve investigating the practical implementation of these principles in schools, rigorously measuring behavioral shifts in students, and assessing the long-term effects on the development of responsible global citizens. Moreover, expanding the study's scope to include a larger, more diverse sample and a broader array of religious perspectives would undoubtedly enhance the comprehensiveness of this framework.

References

- Acharoui, Zakia, Altaf Alaoui, Badia Ettaki, Jamal Zerouaoui, and Mohamed Dakkon. 2020. 'Identifying Political Influencers on YouTube during the 2016 Moroccan General Election'. *Procedia Computer Science* 170 (2018): 1102–9. <https://doi.org/10.1016/j.procs.2020.03.061>.
- Adon, Mathias Jebaru, and Antonius Denny Firmanto. 2022. 'Makna Belas Kasih Allah Dalam Hidup Manusia Menurut Henri JM Nouwen'. *Dunamis : Jurnal Teologi Dan Pendidikan Kristiani* 6 (2): 581–603.
- Agudelo, César Augusto Ruiz, and Angela María Cortes-Gómez. 2021. 'Sustainable Behaviors, Prosocial Behaviors, and Religiosity in Colombia. A First Empirical Assessment'. *Environmental Challenges* 4 (1): 1–12. <https://doi.org/10.1016/j.envc.2021.100088>.
- Ahmadi-Gh, Zahra, and Alejandro Bello-Pintado. 2022. 'Why Is Manufacturing Not More Sustainable? The Effects of Different Sustainability Practices on Sustainability Outcomes and Competitive Advantage'. *Journal of Cleaner Production* 337: 130392. <https://doi.org/10.1016/j.jclepro.2022.130392>.

- Apostolopoulos, Nikolaos, Robert Newbery, and Menelaos Gkartzios. 2018. 'Social Enterprise and Community Resilience: Examining a Greek Response to Turbulent Times'. *Journal of Rural Studies*, no. March: 1–10. <https://doi.org/10.1016/j.jrurstud.2018.03.017>.
- Arshad, Muhammad, Ghulam Abid, Francoise Venezia, and Contreras Torres. 2020. 'Impact of Prosocial Motivation on Organizational Citizenship Behavior'. *Quality & Quantity* 55 (1): 133–50. <https://doi.org/10.1007/s11135-020-00997-5>.
- Aydin Sünbül, Zeynep. 2021. 'Indirect Relations of Mindful Awareness with Different Forms of Prosocial Actions within College Students: The Mediating Role of Empathy'. *Current Psychology* 40 (1): 126–32. <https://doi.org/10.1007/s12144-019-00342-6>.
- Baldassarri, Delia, and Maria Abascal. 2020. 'Diversity and Prosocial Behavior'. *Science* 369 (4 September 2020): 1183–87.
- Banusu, Yakobus Ori, and Antonius Denny Firmanto. 2020. 'Kebahagiaan Dalam Ruang Keseharian Manusia'. *Forum* 49 (2): 51–61. <https://doi.org/10.35312/forum.v49i2.301>.
- Barokah, F, and H Hertanto. 2020. 'Disrupsi Politik: Peluang Dan Tantangan Partai Politik Baru Jelang Pemilu 2024'. *Nakhoda: Jurnal Ilmu Pemerintahan* 21 (1): 1–3.
- Batson, C. Daniel, Kathryn C. Oleson, Joy L. Weeks, Sean P. Healy, Penny J. Reeves, Patrick Jennings, and Thomas Brown. 1989. 'Religious Prosocial Motivation: Is It Altruistic or Egoistic?' *Journal of Personality and Social Psychology* 57 (5): 873–84. <https://doi.org/10.1037/0022-3514.57.5.873>.
- Bernt, Frank M. 1989. 'Being Religious and Being Altruistic: A Study of College Service Volunteers'. *Personality and Individual Differences* 10 (6): 663–69. [https://doi.org/10.1016/0191-8869\(89\)90225-0](https://doi.org/10.1016/0191-8869(89)90225-0).
- Buigut, Steven, and Brain Masinde. 2021. 'The Impact of General Elections on Kenya' s Tourism, Financial, and Media Sector'. *Journal of African Business*, 1–19. <https://doi.org/10.1080/15228916.2021.1874793>.
- Cappellen, Patty Van, Barbara L. Fredrickson, Vassilis Saroglou, and Olivier Corneille. 2017. 'Religiosity and the Motivation for Social Affiliation'. *Personality and Individual Differences* 113: 24–31. <https://doi.org/10.1016/j.paid.2017.02.065>.
- Caprara, Gian Vittorio, Patrizia Steca, Arnaldo Zelli, and Cristina Capanna. 2005. 'A New Scale for Measuring Adults' Prosocialness'. *European Journal of Psychological Assessment* 21 (2): 77–89. <https://doi.org/10.1027/1015-5759.21.2.77>.
- Cret, Remus. 2021. "'You Become One With The Place": Social Mixing, Social Capital, and the Lived Experience of Urban Desegregation in the Roma Community'. *Cities* 117 (2020): 1–10. <https://doi.org/10.1016/j.cities.2021.103302>.
- Epitropaki, Olga, and Robin Martin. 2005. 'From Ideal to Real: A Longitudinal Study of the Role of Implicit Leadership Theories on Leader-Member Exchanges and Employee Outcomes'. *Journal of Applied Psychology* 90 (4): 659–76. <https://doi.org/10.1037/0021-9010.90.4.659>.
- Fadilah, G. 2021. 'Implikasi Teori-Teori Konflik Terhadap Realitas Sosial Masa Kini: Tinjauan Pemikiran Para Tokoh Sosiologi.' *Journal of Society and Development* 13 (1): 11–15.
- FioRito, Taylor A., Clay Routledge, and Jeremy Jackson. 2021. 'Meaning-Motivated Community Action: The Need for Meaning and Prosocial Goals and Behavior'. *Personality and Individual Differences* 171 (1). <https://doi.org/10.1016/j.paid.2020.110462>.
- Firmanto, A.D. 2017. 'Kehadiran Gereja Di Ruang Publik Perspektif Eklesiologis Di Dalam Memandang Keadaan Akhir-Akhir Ini'. *Seri Filsafat Teologi Widaya Sahana* 27: 272–85.
- . 2021a. 'Katekese Virtual Kepada Korban Bencana Alam Di Masa Pandemi Menurut Model Berteologi Kosuke Koyama'. *Religious (Jurnal Studi Agama-Agama Dan Lintas Budaya)* 5 (2): 255–70.
- . 2021b. 'WhatsApp Group Sebagai Ruang Percakapan Pastoral Di Masa Pandemi Covid-19'. *Dunamis – Jurnal Teologi Dan Pendidikan Kristiani* 6 (2): 480–95.
- Gallie, D, Y Zhou, A Felstead, F Green, and G Henseke. 2017. 'The Implications of Direct Participation for Organisational Commitment, Job Satisfaction, and Affective Psychological Well-Being: A Longitudinal Analysis'. *Industrial Relations Journal* 48 (2): 174–91.
- Gannon, Brenda, and Jennifer Roberts. 2018. 'Social Capital: Exploring the Theory and Empirical Divide'. *Empirical Economics*, 1–21. <https://doi.org/10.1007/s00181-018-1556-y>.

- Ganzevoort, R. Ruard, and Johan Roeland. 2014. 'Lived Religion: The Praxis of Practical Theology'. *International Journal of Practical Theology* 18 (1): 91–101. <https://doi.org/10.1515/ijpt-2014-0007>.
- Ghosh, Indrajit, and Maia Martcheva. 2021. 'Modeling the Effects of Prosocial Awareness on Covid-19 Dynamics: Case Studies on Colombia and India'. *Nonlinear Dynamics* 104 (4): 4681–4700. <https://doi.org/10.1007/s11071-021-06489-x>.
- Ghozali, I. 2011. *Structural Equation Modeling Metode Alternatif Dengan Partial Least Square (PLS). Edisi 3*. Badan Penerbit Universitas Diponegoro.
- González-neira, Ana, and Erica Conde-vázquez. 2020. 'Spanish Audience Interest in Televised Politics: From Electoral Debates to Politainment'. *Communication & Society* 33 (3): 85–100. <https://doi.org/10.15581/003.33.3.85-100>.
- Groot, Judith De, and Linda Steg. 2009. 'Morality and Prosocial Behavior: The Role of Awareness, Responsibility, and Norms in the Norm Activation Model'. *Journal of Social Psychology* 149 (4): 425–49. <https://doi.org/10.3200/SOCP.149.4.425-449>.
- Hafenbrack, Andrew C, Lindsey D Cameron, Gretchen M Spreitzer, Chen Zhang, Laura J Noval, and Samah Shaffakat. 2019. 'Organizational Behavior and Human Decision Processes Helping People by Being in the Present: Mindfulness Increases Prosocial Behavior'. *Organizational Behavior and Human Decision Processes*, no. 2018: 1–18. <https://doi.org/10.1016/j.obhdp.2019.08.005>.
- Hair, Joe F., Marko Sarstedt, Lucas Hopkins, and Volker G. Kuppelwieser. 2014. 'Partial Least Squares Structural Equation Modeling (PLS-SEM): An Emerging Tool in Business Research'. *European Business Review* 26 (2): 106–21. <https://doi.org/10.1108/EBR-10-2013-0128>.
- Handoko, Susanto T. 2020. 'Kearifan Lokal Sebagai Modal Sosial Dalam Mengembangkan Perdamaian Di Papua'. *MASA : Journal of History* 1 (2): 94–113. <https://doi.org/10.31571/masa.v1i2.1633>.
- Hendricks, La Velle, Willie Edwards, Tara Tietjen-Smith, and Stephen Reysen. 2022. 'College Students' Awareness and Familiarity with Modern Activism: Prosocial Involvement in Black Lives Matter'. *Journal of Human Behavior in the Social Environment* 32 (4): 534–47. <https://doi.org/10.1080/10911359.2021.1924914>.
- Hilbig, Benjamin E., Andreas Glöckner, and Ingo Zettler. 2014. 'Personality and Prosocial Behavior: Linking Basic Traits and Social Value Orientations'. *Journal of Personality and Social Psychology* 107 (3): 529–39. <https://doi.org/10.1037/a0036074>.
- Huber, Stefan, and Odilo W. Huber. 2012. 'The Centrality of Religiosity Scale (CRS)'. *Religions* 3 (3): 710–24. <https://doi.org/10.3390/rel3030710>.
- Iannone, Aniello. 2022. 'Democracy Crisis in South-East Asia: Media Control , Censorship, and Disinformation during the 2019 Presidential and General Elections in Indonesia, Thailand and 2019 Local Election in the Philippines'. *Jurnal Ilmu Sosial Dan Ilmu Politik* 26 (1): 81–97.
- Ikmal, Mohamad, and Mohamad Arifin. 2020. 'Anarkisme Politik Di Aras Lokal (Peran "Bandit" Politik Dalam Pilkada Di Kabupaten Sumenep)'. *Jurnal Ilmu Politik Dan Pemerintahan* 6 (2): 123–52.
- Jena, L.K. 2014. 'Workplace Spirituality and Work-Life Balance'. *International Journal of Applied Psychology* 4 (4): 155–61. <https://doi.org/10.5923/j.ijap.20140404.04>.
- Kasim, Fajri M, Abidin Nurdin, and M Rizwan. 2021. 'Agama, Modal Sosial Dan Ketahanan Masyarakat Dalam Menghadapi Bencana Di Kota Banda Aceh'. *Jurnal Antropologi: Isu-Isu Sosial Budaya* 23 (1): 66. <https://doi.org/10.25077/jantro.v23.n1.p66-73.2021>.
- Kharlie, Ahmad Tholabi. 2023. "'Civil Society" Dan Penguatan Nilai Kemanusiaan'. *Kompas*, 2023.
- Khozin, Wahid. 2013. 'Sikap Keagamaan Dan Potensi Radikalisme Agama Mahasiswa Perguruan Tinggi Agama'. *Edukasi: Jurnal Penelitian Pendidikan Agama Dan Keagamaan* 11 (3): 289–304. <https://doi.org/10.32729/edukasi.v11i3.415>.
- Kim, Haemi, and Hailin Qu. 2020. 'The Mediating Roles of Gratitude and Obligation To Link Employees' Social Exchange Relationships and Prosocial Behavior'. *International Journal of Contemporary Hospitality* 32 (2): 644–64. <https://doi.org/10.1108/IJCHM-04-2019-0373>.
- Knudsen, Eirik Sjøholm, Lasse B. Lien, Bram Timmermans, Ivan Belik, and Sujit Pandey. 2021. 'Stability in Turbulent Times? The Effect of Digitalization on the Sustainability of Competitive Advantage'. *Journal of Business Research* 128 (February): 360–69. <https://doi.org/10.1016/j.jbusres.2021.02.008>.

- Kurnia, Novi, and Santi Indra Astuti. 2017. 'Peta Gerakan Literasi Digital Di Indonesia: Studi Tentang Pelaku, Ragam Kegiatan, Kelompok Sasaran Dan Mitra'. *Informasi: Kajian Ilmu Komunikasi* 47 (2): 149–66. <https://doi.org/10.21831/informasi.v47i2.16079>.
- Lambert, Nathaniel M., Tyler F. Stillman, Joshua A. Hicks, Shanmukh Kamble, Roy F. Baumeister, and Frank D. Fincham. 2013. 'To Belong Is to Matter: Sense of Belonging Enhances Meaning in Life'. *Personality and Social Psychology Bulletin* 39 (11): 1418–27. <https://doi.org/10.1177/0146167213499186>.
- Lee, Juheon. 2019. 'Bonding and Bridging Social Capital And Their Associations With Self - Evaluated Community Resilience: A Comparative Study of East Asia'. *Journal of Community and Applied Social Psychology*, no. March: 1–14. <https://doi.org/10.1002/casp.2420>.
- Letsoin, Y.S., A.D. Firmanto, and N.W Aluwesia. 2021. 'Gereja Partisipatif-Memasyarakat Di Tengah Pandemi Covid-19'. *Media: Jurnal Filsafat Dan Teologi* 3 (2): 221–38.
- Li, Kaijian, Ruopeng Huang, Guiwen Liu, and Asheem Shrestha. 2022. 'Social Capital in Neighbourhood Renewal : A Holistic and State of the Art Literature Review'. *Land* 11 (1202): 1–27.
- Lord, Robert G., Paola Gatti, and Susanna L.M. Chui. 2016. 'Social-Cognitive, Relational, and Identity-Based Approaches to Leadership'. *Organizational Behavior and Human Decision Processes* 136: 119–34. <https://doi.org/10.1016/j.obhdp.2016.03.001>.
- Manala, Matsobane J. 2018. 'Gratitude as a Christian Lifestyle: An Afro-Reformed Theological Perspective'. *HTS Teologiese Studies / Theological Studies* 74 (4): 1–8. <https://doi.org/10.4102/hts.v74i4.5117>.
- McDaniel, June. 2015. 'Indonesia, Modernity and Some Problems of Religious Adaptation'. *Wacana* 15 (2): 314. <https://doi.org/10.17510/wacana.v15i2.406>.
- Meng, Jie. 2022. 'The More We Know, The More Likely We May Agree?' *Telematics and Informatics* 70 (September 2021): 101807. <https://doi.org/10.1016/j.tele.2022.101807>.
- Mikovi, Radmila, Dejan Petrovi, Marko Mihi, Vladimir Obradovi, and Marija Todorovi. 2020. 'The Integration of Social Capital and Knowledge Management – The Key Challenge For International Development and Cooperation Projects of Nonprofit Organizations'. *International Journal of Project Management* 10: 1–19. <https://doi.org/10.1016/j.ijproman.2020.07.006>.
- Mittal, Rakesh, and Peter W. Dorfman. 2012. 'Servant Leadership Across Cultures'. *Journal of World Business* 47 (4): 555–70. <https://doi.org/10.1016/j.jwb.2012.01.009>.
- Murray, Brittany, and Amy Petts. 2020. "'We'Re in This Together'": Bridging and Bonding Social Capital in Elementary School PTOs'. *American Educational Research Journal* 20 (10): 1–35. <https://doi.org/10.3102/0002831220908848>.
- Mustapha, Lambe Kayode, and Bahiyah Omar. 2020. 'Do Social Media Matter? Examining Social Media Use And Youths' Political Participation During The 2019 Nigerian General Elections'. *The Round Table* 109 (4): 441–57. <https://doi.org/10.1080/00358533.2020.1788766>.
- Mustapha, Lambe Kayode, Bahiyah Omar, Fitria Barokah, Tabah Maryanah, Ari Darmasturi, Matthew Warren, Zakia Acharoui, et al. 2020. 'Spanish Audience Interest in Televised Politics: From Electoral Debates to Politainment'. *Procedia Computer Science* 170 (4): 1–12. <https://doi.org/10.1080/00358533.2020.1788766>.
- Neugebauer, Richard, Priya Wickramaratne, Connie Svob, Clayton H. McClintock, Marc J. Gameroff, Lisa Miller, and Anne Conway. 2020. 'Contribution of Religion/Spirituality and Major Depressive Disorder to Altruism'. *Journal of Affective Disorders* 262 (September 2019): 16–22. <https://doi.org/10.1016/j.jad.2019.10.031>.
- Noble, Nicholas Rory Raphael. 2020. 'Paideia as Pious Preparation'. *Norwegian School of Theology*.
- Pfattheicher, Stefan, Yngwie Asbjørn Nielsen, and Isabel Thielmann. 2022. 'Prosocial Behavior and Altruism: A Review of Concepts and Definitions'. *Current Opinion in Psychology* 44: 1–15. <https://doi.org/10.1016/j.copsyc.2021.08.021>.
- Piatak, Jaclyn S, and Stephen B Holt. 2019. 'Prosocial Behaviors: A Matter of Altruism or Public Service Motivation?' *Journal of Public Administration Research and Theory*, 1–15. <https://doi.org/10.1093/jopart/muz041>.



- Preston, Jesse Lee, Ryan S. Ritter, and J. Ivan Hernandez. 2010. 'Principles of Religious Prosociality: A Review and Reformulation'. *Social and Personality Psychology Compass* 4 (8): 574–90. <https://doi.org/10.1111/j.1751-9004.2010.00286.x>.
- Ramus, Tommaso, Barbara La Cara, Antonino Vaccaro, and Stefano Brusoni. 2018. 'Social or Commercial? Innovation Strategies in Social Enterprises at Times of Turbulence'. *Business Ethics Quarterly*. <https://doi.org/10.1017/beq.2017.55>.
- Rasdi, Roziah Mohd. 2020. 'Knowledge-Sharing Behaviour in Public Service Organisations: Determinants and the Roles of Affective Commitment and Normative Commitment'. *European Journal of Training and Development*, 1–19. <https://doi.org/10.1108/EJTD-02-2020-0028>.
- Ridge-newman, Anthony. 2020. 'Digital Media As A Driver Of Change In Political Organisation: 2010 And 2015 UK General Elections'. *Media Culture & Society*. <https://doi.org/10.1177/0163443720916398>.
- Routledge, Clay, Jamie Arndt, Tim Wildschut, Constantine Sedikides, Claire M. Hart, Jacob Juhl, Ad J.J.M. Vingerhoets, and Wolff Schlotz. 2011. 'The Past Makes the Present Meaningful: Nostalgia as an Existential Resource'. *Journal of Personality and Social Psychology* 101 (3): 638–52. <https://doi.org/10.1037/a0024292>.
- Saroglou, Vassilis. 2012. 'Religion, Spirituality, and Altruism.' *APA Handbook of Psychology, Religion, and Spirituality (Vol 1): Context, Theory, and Research*. 1: 439–57. <https://doi.org/10.1037/14045-024>.
- Saroglou, Vassilis, Magali Clobert, Adam B. Cohen, Kathryn A. Johnson, Kevin L. Ladd, Matthieu Van Pachterbeke, Lucia Adamovova, et al. 2020. 'Believing, Bonding, Behaving, and Belonging: The Cognitive, Emotional, Moral, and Social Dimensions of Religiousness across Cultures'. *Journal of Cross-Cultural Psychology* 51 (7–8): 551–75. <https://doi.org/10.1177/0022022120946488>.
- Sharma, Ankita, and Udayan Ghose. 2020. 'Sentimental Analysis of Twitter Data with Respect to General Elections in India'. *Procedia Computer Science* 173 (2019): 325–34. <https://doi.org/10.1016/j.procs.2020.06.038>.
- Sidler, Petra, Wassilis Kassis, Elena Makarova, and Clarissa Janousch. 2021. 'Assessing Attitudes towards Mutual Acculturation in Multicultural Schools: Conceptualisation and Validation of a Four-Dimensional Mutual Acculturation Attitudes Scale'. *International Journal of Intercultural Relations* 84 (June): 300–314. <https://doi.org/10.1016/j.ijintrel.2021.08.009>.
- Silke, Charlotte, Bernadine Brady, Ciara Boylan, and Pat Dolan. 2018. 'Factors Influencing the Development of Empathy and Pro-Social Behaviour among Adolescents: A Systematic Review'. *Children and Youth Services Review* 94: 421–36. <https://doi.org/10.1016/j.childyouth.2018.07.027>.
- Steger, Michael F., Todd B. Kashdan, Brandon A. Sullivan, and Danielle Lorentz. 2008. 'Understanding the Search for Meaning in Life: Personality, Cognitive Style, and the Dynamic between Seeking and Experiencing Meaning'. *Journal of Personality* 76 (2): 199–228. <https://doi.org/10.1111/j.1467-6494.2007.00484.x>.
- Sukanto, Amos, and S Panca Parulian. 2020. 'Religious Community Responses to the Public Policy of the Indonesian Government Related to the Covid-19 Pandemic' 8: 273–83. <https://doi.org/10.1163/22124810-2020006>.
- Sulphey, M. M., and Ansa Salim. 2021. 'Development of a Tool to Measure Social Entrepreneurial Orientation'. *Journal of Entrepreneurship in Emerging Economies* 13 (2): 231–53. <https://doi.org/10.1108/JEEE-07-2019-0099>.
- Taroreh, Tomy, Antonius Denny Firmanto, and Nanik Wijiyati Aluwesia. 2021. 'Gereja Mengumat Di Masa Pandemi Covid-19'. *JPAK: Jurnal Pendidikan Agama Katolik* 21 (2): 74–96. <https://doi.org/10.34150/jpak.v21i2.300>.
- Tsang, Jo Ann, Rosemary L. Al-Kire, and Juliette L. Ratchford. 2021. 'Prosociality and Religion'. *Current Opinion in Psychology* 40: 67–72. <https://doi.org/10.1016/j.copsyc.2020.08.025>.
- Underwood, Lynn G. 2011. 'The Daily Spiritual Experience Scale: Overview and Results'. *Religions* 2: 29–50. <https://doi.org/10.3390/rel2010029>.
- Untea, Ionut. 2018. 'Contemporary Uses of the Golden Rule of Reciprocity in Abrahamic Interfaith Discourses'. *Studies in Religion-Sciences Religieuses* 47 (1): 107–36. <https://doi.org/10.1177/0008429817721904>.

- Utama, I Wayan Budi. 2012. 'Turbulensi Sosial Dan Membangun Modal Sosial'. *Widyanatya: Jurnal Pendidikan Agama Dan Seni* 2 (1): 63–72.
- Warren, Matthew. 2020. 'Fake News Case Study during the Australian 2019 General Election'. *Australasian Journal of Information Systems* 24: 1–12.
- Wei, Jason, Jian Ng, Gary J Rangel, Yet Chin Phung, Jason Wei, and Jian Ng. 2020. 'Malaysia' s 14th General Election: Dissecting the "Malaysian Tsunami"— Measuring the Impacts of Ethnicity and Urban Development on Electoral Outcomes'. *Asian Journal of Political Science*, 1–25. <https://doi.org/10.1080/02185377.2020.1814363>.
- Xia, Weiwei, Xiaohan Guo, Jun Luo, Hang Ye, Yefeng Chen, Shu Chen, and Weisen Xia. 2021. 'Religious Identity, Between-Group Effects and Prosocial Behavior: Evidence from A Field Experiment in China'. *Journal of Behavioral and Experimental Economics* 91 (January): 101665. <https://doi.org/10.1016/j.socec.2021.101665>.
- Zaenuddin, Dundin, Yekti Maunati, I Ketut Ardhana, and Dicky Sofjan. 2022a. 'A Social Capital in Contemporary Indonesia: Examining Faith-Inspired Civil Society and Democracy'. *Religio: Jurnal Studi Agama-Agama* 12 (2): 211–32. <https://doi.org/10.15642/religio.2022.12.2.211-232>.
- . 2022b. 'Social Capital In Contemporary Indonesia: Examining Faith-Inspired Civil Society and Democracy'. *Religio: Jurnal Studi Agama-Agama* 12 (2): 211–32.
- Zhang, Wei, Sunny Li Sun, Yuan Jiang, and Wenyao Zhang. 2019. 'Openness to Experience and Team Creativity: Effects of Knowledge Sharing and Transformational Leadership'. *Creativity Research Journal* 31 (1): 62–73. <https://doi.org/10.1080/10400419.2019.1577649>.
- Zhi, Sebastian, Tao Khoo, Leong Hock Ho, Ee Hong Lee, Danston Kheng, Boon Goh, Zehao Zhang, Swee Hong Ng, Haodi Qi, and Kyong Jin Shim. 2020. 'Social Media Analytics: A Case Study of Singapore General Election 2020'. In *2020 IEEE International Conference on Big Data*, 5730–32.

Faith-Inspired Interrelational Citizenship: a Key Driver for Cultivating Peace in The Indonesian Socio-Political Landscapes

Antonius Denny Firmanto^{1,2,*}, Emiliana Sri Pudjiarti³, Alphonsus Tjatur Raharso¹, Edison R.L. Tinambunan¹

Author Note

Antonius Denny Firmanto   ^{1,2,*} <https://orcid.org/0000-0001-7590-5654>

¹Sekolah Tinggi Filsafat Teologi Widya Sasana, Malang, East Java 65146, Indonesia

²Pontificia Università Urbaniana, Via Urbano, 00165 Rome, Italy

fantoniusedenny@gmail.com

Emiliana Sri Pudjiarti   ³ <https://orcid.org/0000-0002-7612-1031>

³Universitas 17 Agustus 1945 Semarang, Central Java 50133, Indonesia

emiliana-sripujiarti@untagsmg.ac.id

Alphonsus Tjatur Raharso   ¹ <https://orcid.org/0009-0004-0787-7574>

¹Sekolah Tinggi Filsafat Teologi Widya Sasana, Malang, East Java 65146, Indonesia

alphonsustjaturraharso@gmail.com

Edison R.L. Tinambunan   ¹ <https://orcid.org/0000-0003-1656-927X>

¹Sekolah Tinggi Filsafat Teologi Widya Sasana, Malang, East Java 65146, Indonesia

edisontinambunan750@gmail.com

We have no known conflict of interest to disclose.

Correspondence concerning this article should be addressed to Antonius Denny Firmanto

*Email: fantoniusedenny@gmail.com

December 2023

Faith-Inspired Interrelational Citizenship: a Key Driver for Cultivating Peace in The Indonesian Socio-Political Landscapes

Antonius Denny Firmanto^{1,2,*}, Emiliana Sri Pudjiarti³, Alphonsus Tjatur Raharso¹, Edison R.L. Tinambunan¹

¹Sekolah Tinggi Filsafat Teologi Widya Sasana, Malang, East Java 65146, Indonesia

²Pontificia Università Urbaniana, Via Urbano, 00165 Rome, Italy

³Universitas 17 Agustus 1945 Semarang, Central Java 50133, Indonesia

*Email Correspondence: fantoniusedenny@gmail.com

Abstract: This study analyzed the influence of awareness of humanitarian mission vocations, meaningful living, prosocial engagement, and spiritual engagement on faith-inspired inter-relational citizenship and local and religious values. The findings showed the positive and significant impact of these aspects in shaping values and deep relational relationships. The integration of religious values in education was recognized as a means to increase global awareness, empathy, and intercultural cooperation. However, the potential for exclusivity and value conflicts was also recognized. Future research recommendations engaged broader stakeholders and measured the real impact on student behavior. Weaknesses of this study included limitations in participants and the generalizability of findings. Overcoming these limitations could enrich our understanding of the role of integrating religious values in shaping responsible and competitive global citizens.

Keywords: awareness of mission calls for humanity; faith-inspired interrelational citizenship; meaningful life; prosocial engagement; spiritual engagement

1. Introduction

Disruption is the theme of the Industrial Revolution Era 4.0 and Society 5.0. (Barokah & Hertanto, 2020). Turbulent conditions are one of the fruits of disruption (Knudsen et al. 2021). It is suspected that turbulent conditions have characteristics of volatile, uncertain, complex, ambiguous, irregular, and random will color the process of the political year ahead of the 2024 elections (Ramus et al. 2018). The prediction arises from experience in English (Ikmal & Arifin, 2020) and abroad (Buigut & Masinde, 2021; Wei et al., 2020). The turbulence of the political field affects the economic, social, and resilience of society. Identity politics and societal polarization are two possible strategies that emerge in electoral contestation. Social turbulence: a kind of irregular and random social movement, in the form of political discourse that develops without direction, economic discourse haunted by recession and inflation, social discourse tainted by violence, and cultural discourse without value (Arshad et al. 2020). Turbulence consumes social energy because its content is a commotion whose fruit is a trap of the moment Inertia, a state of walking in place (Main, 2012).

The use of social media also affects the turbulent conditions of the political year (Barokah & Hertanto, 2020). Research (Mustapha et al. 2020; Sharma and Ghose 2020; Meng 2022). Finding that Social Media Affects Vote Gain (Ridge-Newman, 2020). Social media becomes a medium of debate influencers Social media that consumes energy and drags society into polarization, segmentation, and segregation as happened in India, Spain (González-neira and Conde-vázquez 2020; Mustapha et al. 2020)Nigeria (Mustapha & Omar, 2020), and Morocco (Acharoui et al. 2020), as well as Singapore (Zhi et al. 2020). Reflecting on the experience of other countries, according to conflict theory, the sequence of the 2024 Indonesian election process has the potential to result in conflict escalation (Fadilah 2021). Escalation occurs because interested parties will take advantage of existing issues to attract the interest of voters (Kurnia & Astuti, 2017; Mustapha & Omar, 2020; Warren, 2020), and allegedly one of the issues that will pass on social media is the issue of populism in identity politics (Iannone 2022).

This phenomenon raises questions about the existence of issues that will pass on social media (Firmanto 2021a; 2021b). Will those issues lead society to the turbulence of the political year? What are the actions of the community in response to hoaxes and fake news? Is there hope for peace and harmony? (Adon & Firmanto, 2022; Letsoin et al., 2021; Taroreh et al., 2021).

It is assumed that everyone knows the universal values of humanity, both from religious sources (Firmanto 2017) and sources of Local Culture (Handoko 2020; Noble 2020; Preston, Ritter, and Ivan Hernandez 2010). Such recognition will give rise to the hope of living in harmony (Arshad et al., 2020; Epitropaki & Martin, 2005; Lord et al., 2016). Research results (Hendricks et al. 2022; Ghosh and Martcheva 2021; Aydin Sünbül 2021; De Groot and Steg 2009) show that social consciousness is effective and experienced. The researcher assumes that in the Indonesian context, the experience of religiosity in togetherness with the community will affect the feeling of peace, calm, harmony, and solidarity in the community from a theoretical perspective of bridging and bonding (Lee, 2019; Mittal & Dorfman, 2012; Murray & Petts, 2020; Saroglou et al., 2020; Sulphrey & Salim, 2021). This study proposes the statement that faith-inspired interrelational citizenship will be the catalyst for its realization of Justice, Peace, and Social Integration Based on Local and Religious Values (Zaenuddin et al. 2022a).

Research (Gannon and Roberts 2018; Li et al. 2022) indicates that reinforcement Social capital is one of the strategies to get out of moments of inertia. The social capital that is the material object of this study is Civil Society in the form of community-based educational institutions (Rasdi 2020; Zhang et al. 2019; Hafenbrack et al. 2019). Empirically, the experience of community-based educational institutions in Greece is one of the factors in the country's release from turbulent situations as a result of the political process (Apostolopoulos, Newbery, and Gkartzios 2018). Based on this experience, the data unit of civil society in the form of Community-based educational institutions in Indonesia are believed to have the ability to receive, manage, and assess as well as respond to social media information to survive the turbulence of the political year (Eunuch et al., 2021; Kharlie, 2023; Sukamto & Parulian, 2020).

2. Theoretical Foundation

The concept of faith-inspired interrelational citizenship (FIC) in a harmonious and peaceful society is a synthesis of Social Exchange theory, Social Capital theory, and Prosocial Behavior theory (Agudelo & Cortes-Gómez, 2021; Untea, 2018; Xia et al., 2021; Zaenuddin et al., 2022).

Social Exchange theory states that the continuity of the relationship of two or more individuals depends on the exchange that occurs. Each individual voluntarily enters and stays in social relationships only as long as those relationships are satisfactory (Ahmadi-Gh and Bello-Pintado 2022; Kim and Qu 2020; Lord, Gatti, and Chui 2016).

Next Social Capital Theory states that society is an organism that can declare its existence (Cret, 2021; Gannon & Roberts, 2018; Mikovi et al., 2020; Murray & Petts, 2020). Social capital has aspects of: 1) reciprocal trust, that is, to think and act positively towards others; 2) solidarity, i.e. social solidarity; 3) tolerance, i.e. willingness to sacrifice in bearing differences of opinion, creed, or habit; 4) equality, i.e. Acknowledgment of correspondence and break even with getting to the assets of life (such as social, social, and political economy; 5) social systems and organizations (affiliations), i.e., gatherings or media of social relations; and 6) interest (Civic Engagement) and participation, that's, the support of an individual in his community and participation to attain the common great (Banusu & Firmanto, 2020).

Prosocial Behavior theory explains the existence of voluntary actions of an individual or a group intended to help or benefit another individual or group of individuals (Fiorito et al., 2021; Hilbig et al., 2014; Piatak & Holt, 2019; Silke et al., 2018; Tsang et al., 2021). Faith-inspired Correlational Citizenship (FIC) is a willingness to meet, work together, and share information to realize a new value that is aspired to together is encouraged by the main religious values (Agudelo & Cortes-Gómez, 2021; Batson et al., 1989; Fiorito et al., 2021; Preston et al., 2010; Saroglou, 2012; Tsang et al., 2021; Xia et al., 2021). FIC Concept is a relationship model that describes the concept of bridging and bonding in a democratic society that is imagined to produce a feeling of comfort (affective aspect) that reinforces organizational commitment in an individual (Pfattheicher, Nielsen, and Thielmann 2022; Preston, Ritter, and Ivan

Hernandez 2010; Tsang, Al-Kire, and Ratchford 2021). Aspects faith-inspired became a distinctive aspect of the FIC concept because the maturity of religiosity resulted in peace, justice, and solidarity.

Table 1. State of the art of Faith-Inspired Interrelational Citizenship (FIC)

Researchers	Dimension	Definition	Indicators
(Gallie et al. 2017; Underwood 2011; Manila 2018; Kim and Qu 2020)	Feelings of gratitude	A response to life experiences that results in peace of heart and peace of mind.	Take time for reflection. Be grateful for life. Thanks to others for positive influences.
(Funk, 2021; Khan et al., 2019; Sumbulah, 2015; Thomas & Rowland, 2014; Underwood, 2011)	Awareness of the mission calls for humanity	The belief is that human sociality serves to reduce suffering and build life together.	Altruistic compassion Sharing possessions (money/time/energy/thoughts) Volunteerism in kindness Working together for a better quality of life
(Jena 2014; Huber and Huber 2012; Lambert et al. 2013; Routledge et al. 2011; Steger et al. 2008; FioRito, Routledge, and Jackson 2021)	Meaningful life	The belief that life itself is meaningful so that people are willing to construct their lives based on universal values.	Be open to new situations Have a purpose in life Balancing social and personal life Have an expression that values life
(Agudelo & Cortes-Gómez, 2021; Ganzevoort & Roeland, 2014; Neugebauer et al., 2020)	Spiritual engagement	Involvement in spiritual beliefs and practices.	Ponder topics such as pain, suffering, or death. Improve the quality of relationships with others. Show empathy and generosity.
(Arshad et al., 2020; Baldassarri & Abascal, 2020; FioRito et al., 2021; Piatak & Holt, 2019; Preston et al., 2010; Saroglou, 2012; Silke et al., 2018; Tsang et al., 2021)	Prosocial engagement	Social behavior is contributive to other individuals or groups.	reciprocal trust solidarity Tolerance gender equality Same access Social Network Civic Engagement Positive attitude towards plurality

3. Hypotheses Development

H1: There is a significant relationship between awareness of mission calls for humanity and faith-inspired inter-relational citizenship.

Mission awareness calls for humanity and refers to the recognition and understanding of significant social or global challenges that require collective action. This concept suggests that when people are aware of an urgent mission, such as tackling climate change or promoting equality, they are more inclined to collective action. By recognizing the urgency of this mission, individuals and groups can hypothesize potential causes, impacts, and interventions, thus encouraging proactive problem-solving. This awareness-driven hypothesis construction aligns with a shared commitment to creating innovative solutions. Positive impact on the world, encouraging thoughtful exploration and experimentation to drive meaningful change (Gallie et al. 2017; Manila 2018; Kim and Qu 2020; Underwood 2011).

Faith-inspired inter-relational citizenship includes the idea of individuals leveraging their spiritual beliefs to foster positive relationships among diverse communities. This concept suggests that faith-based principles can inspire individuals to engage in active citizenship, transcending cultural and religious boundaries. By investigating this phenomenon, hypotheses can explore how beliefs-driven values influence attitudes toward inclusivity, cooperation, and social responsibility. In addition, research can investigate whether faith-based interactions improve intergroup relationships and enhance a sense of shared humanity. By examining the relationship between faith, inter-relational dynamics, and citizenship, hypotheses can contribute to a deeper understanding of how spirituality shapes community engagement.

H2: There is a significant relationship between awareness of mission calls for humanity and local and religious values.

Local and religious values as the cornerstone of humanitarian mission vocation awareness are concerned with the influence of community-specific and spiritual beliefs in fostering awareness of critical global challenges. The concept argues that people's attachment to local and religious values can increase their recognition of urgent missions such as environmental conservation or social justice. Building research hypotheses in this context can explore how these values shape individuals' perceptions of global issues, their willingness to engage in collective action, and the effectiveness of awareness campaigns rooted in cultural and religious narratives. Investigating these relationships provides insight into harnessing local beliefs to foster broader awareness and impactful change (Gallie et al. 2017; Manila 2018; Kim and Qu 2020; Underwood 2011).

H3: There is a significant relationship between meaningful life and faith-inspired inter-relational citizenship.

Meaningful life refers to the sense of purpose, fulfillment, and satisfaction an individual experiences in their existence. It is often associated with a deeper understanding of one's values, and goals, and a sense of connection to something greater than oneself (Steger, Frazier, Oishi, & Kaler, 2006). Research has shown People with a better sense of meaning in life tend to show more noteworthy mental well-being, upgraded versatility, and expanded pro-social behaviors (Martela & Steger, 2016). Faith-inspired interrelational citizenship alludes to the dynamic engagement and interest of people from assorted confidence foundations in cultivating positive connections and participation inside a community. It includes advancing understanding, sympathy, and collaborative endeavors based on shared values and convictions motivated by confidence (Berkowitz & Grych, 1998). This citizenship shape is vital in building social cohesion, improving common regard, and bridging isolation between devout and social bunches (Djupe & Gilbert, 2003).

The framework proposes that a meaningful life can catalyze individuals to engage in faith-inspired interrelational citizenship. When individuals find purpose and significance in their lives, they are more likely to develop a broader perspective that transcends personal interests. This expanded worldview often leads to more vital empathy and compassion towards others, regardless of their religious or cultural backgrounds (Emmons, 2003). Studies have indicated that individuals with a higher sense of meaning in life are more inclined to engage in pro-social behaviors and display more significant concern for the well-being of others (van Tongeren, Green, Davis, Hook, & Hulseley, 2016). Furthermore, research has shown that faith-inspired practices can foster a sense of interconnectedness and common humanity among individuals from different religious backgrounds (Ritter, Preston, & Hernandez, 2016).

H4: There is a significant relationship between meaningful life and local and religious values.

Significant life alludes to the subjective discernment of people that their lives are noteworthy, deliberate, and satisfying. It includes a sense of coherence, heading, and understanding of one's values, objectives, and reason in life (Steger, Frazier, Oishi, & Kaler, 2006). Individuals with a better sense of meaning in life tend to involve more prominent mental well-being and general life fulfillment (Steger, Kashdan, & Oishi, 2008). Neighborhood values include the social and societal standards, conventions, and convictions predominant inside a particular community or topographical locale. These values frequently shape the personality and hones of the community individuals and impact their states of mind

and behaviors (Triandis, 1995). Devout values, conversely, are the moral standards, ethical rules, and otherworldly convictions determined from devout lessons and teachings (Slope & Pargament, 2003). These values direct the conduct and choices of disciples and play a central part in their daily lives.

The system proposes a forbidden relationship between an individual's sense of significant life and adherence to nearby and devout values. Nearby and holy values give people an ethical compass and a system for understanding their reason and part inside their community and otherworldly setting (Wong, Reker, & Gesser, 1993). In turn, a vital life can strengthen the significance of these values and encourage their integration into one's way of life. Various things have investigated the association between devout values and the discernment of significant life. Inquire has found that people who emphasize their righteous convictions and hones report a more noteworthy sense of meaning and reason (Krause, 2003; Lambert, Stillman, Baumeister, Fincham, Hicks, Graham, 2010). Adherence to nearby values and social conventions has been related to a more grounded sense of personality, social having a place, and life fulfillment (Cohen, 2009; Uskul & Over, 2016).

Besides, it has appeared that people who coordinate their devout values into their everyday lives involve the next level of mental well-being and flexibility, contributing to a more noteworthy recognition of life's importance (Slope & Pargament, 2003; Stop, 2010).

H5: There is a significant relationship between spiritual engagement and faith-inspired inter-relational citizenship.

Spiritual Engagement raised from Faith-Inspired Inter-Relational Citizenship" encapsulates the idea of individuals deriving heightened spiritual involvement through their commitment to cross-cultural, faith-driven citizenship. This concept suggests that engaging in positive interactions across religious boundaries can deepen one's spiritual connection and sense of purpose (Agudelo & Cortes-Gómez, 2021; Ganzevoort & Roeland, 2014; Neugebauer et al., 2020). Constructing research hypotheses around this concept could explore how faith-based inter-relational interactions influence individuals' spiritual experiences, personal growth, and community contributions. Further investigation might delve into whether these experiences lead to enhanced well-being and a more profound sense of interconnectedness. By studying the relationship between faith, inter-relational citizenship, and spiritual engagement, hypotheses can shed light on the complex interplay of these factors.

H6: There is a significant relationship between spiritual engagement and local and religious values.

Spiritual Engagement based on Local and Religious Values entails individuals cultivating a deeper spiritual connection by aligning their beliefs with local customs and religious principles. This concept proposes that integrating cultural and religious values can enhance spiritual experiences and personal growth. Research hypotheses within this context might explore how these values contribute to individuals' sense of purpose, well-being, and community involvement. Additionally, investigations could examine whether spiritual engagement rooted in local and religious contexts leads to greater empathy, social responsibility, and cross-cultural understanding. By probing the interplay between spirituality, values, and engagement, hypotheses can offer insights into fostering meaningful connections and enriching lives (Agudelo & Cortes-Gómez, 2021; Ganzevoort & Roeland, 2014; Neugebauer et al., 2020).

H7: There is a significant relationship between prosocial engagement and faith-inspired inter-relational citizenship.

The connection between prosocial engagement and faith-inspired inter-relational citizenship explores how individuals driven by faith-based inter-relational principles are more likely to exhibit prosocial behaviors. This concept suggests that religious values encouraging inclusive interactions across diverse groups can inspire actions benefiting others and the community. Constructing research hypotheses around this concept could investigate how such citizenship fosters empathy, cooperation, and altruism (Arshad et al., 2020; Baldassarri & Abascal, 2020; Fiorito et al., 2021; Piatak & Holt, 2019; Preston et al., 2010; Saroglou, 2012; Silke et al., 2018; Tsang et al., 2021). Additionally, hypotheses might explore whether the motivation drawn from faith-driven inter-relational principles leads to increased volunteerism, charitable activities, and social support networks. By examining the correlation between faith-

inspired citizenship and prosocial engagement, research can unveil pathways to harnessing spirituality for societal betterment.

H8: There is a significant relationship between prosocial engagement and local and religious values.

The connection between prosocial engagement and local and religious values centers on how individuals influenced by their cultural and religious beliefs tend to exhibit higher levels of prosocial behavior. This concept suggests that values rooted in local traditions and spiritual teachings can inspire actions that benefit others and the community (Arshad et al., 2020; Baldassarri & Abascal, 2020; Fiorito et al., 2021; Piatak & Holt, 2019; Preston et al., 2010; Saroglou, 2012; Silke et al., 2018; Tsang et al., 2021). Constructing research hypotheses around this concept involves exploring how these values contribute to empathy, cooperation, and altruism. Additionally, hypotheses could delve into whether individuals guided by local and religious values are more likely to engage in volunteering, charitable acts, and fostering social bonds. By examining this correlation, research can uncover ways to leverage cultural and religious values to promote prosocial engagement.

H9: There is a significant relationship between faith-inspired inter-relational citizenship and local and religious values.

The connection between Faith-Inspired Inter-Relational Citizenship and Local and Religious Values explores how individuals who practice faith-driven inter-relational citizenship often draw upon their local cultural and religious values to guide their actions. This concept suggests that embracing diverse faith-based principles can enhance cross-cultural understanding, empathy, and community engagement. Constructing research hypotheses within this framework involves investigating how these values shape individuals' approaches to intergroup interactions, cooperation, and societal contributions. Additionally, hypotheses might explore whether faith-inspired inter-relational citizenship fosters a sense of shared humanity and promotes social harmony by bridging differences. By studying this connection, research can illuminate ways to harmonize faith, values, and citizenship for a more inclusive and interconnected society (Arshad et al., 2020; Baldassarri & Abascal, 2020; Fiorito et al., 2021; Piatak & Holt, 2019; Preston et al., 2010; Saroglou, 2012; Silke et al., 2018; Tsang et al., 2021).

4. Research Method

This study uses mixed methods. Design sequential explanatory models on qualitative approaches to find patterns and test hypotheses. Data collection techniques using questionnaires, in-depth interviews, documentation, and triangulation, with research instruments: tests, questionnaires, standard instruments, notebooks, tape recorder, camera, and handycam. Hypothesis testing is proven by the support of qualitative data and quantitative data. The research object is civil society in the form of community-based educational institutions in the form of formal educational institutions in East Java, namely the Karmel Foundation (Catholic religious base), the Aletheia Indonesia Christian Foundation (Christian religious base), Jatim LP Ma'arif NU (Islamic religious base), the Pasraman Ganesha Parwati Foundation (Hindu religious base) and the Buddhist Education Foundation (Buddhist religious base). The units of observation are foundation administrators, teachers, and educational staff.

The sample number is 234 respondents, this number already meets the SEM processing requirements (Hair et al. 2014). SEM-PLS to assess outer and inner structural models and test hypotheses. Outer assessment to evaluate validity, consisting of average variance extracted test, loading factor, and Fornell lesser criteria. Reliability evaluation through composites. Fit is assessed on each path in the model by evaluating R2 measurements, predictive relevance Q2, and significance of path coefficients, f2, and q2 evaluations (Ghozali 2011). Qualitative testing tools are instruments for understanding, analyzing, and interpreting data that is descriptive and complex.

Table 2. Instruments

Variable	Instruments	References
Independent	A New Scale for Measuring Adults' Prosocialness	(Caprara et al. 2005)

	Religious Identity, Between-Group Effects and Pro-social Behavior: Evidence from A Field Experiment in China	(Xia et al. 2021)
	Religiosity and the Motivation for Social Affiliation	(Van Cappellen et al. 2017)
	Meaningful life	
	Spiritual engagement	
Dependent	Assessing Attitudes towards Mutual Acculturation in Multicultural Schools: Conceptualization and Validation of a Four-Dimensional Mutual Acculturation Attitudes Scale	(Sidler et al. 2021)
	Being Religious and Being Altruistic: A Study of College Service Volunteers	(Bernt 1989)
Intervening	Faith-inspired Interrelational Citizenship (FIC) scales	(Zaenuddin et al. 2022b; Huber and Huber 2012; McDaniel 2015; Khozin 2013)

5. Result of Quantitative Analysis

Outer Model Evaluation

There are 2 (two) second-order variables, namely: Faith-inspired inter-relational citizenship and local and religious values, and 4 (four) first-order variables. The results of the evaluation of validity and reliability for each construct in the measurement model are shown in Table 3 which summarizes the criteria of loading factor, Cronbach's Alpha, AVE, and composite reliability for each construct in this study.

Table 3: Validity and reliability criteria for each construct

Variable	Dimension and indicator	Sym- bol	Load- ing Fac- tor ^{*)}	Cronbach's Alpha ^{**)}	Composite Reliability ^{***)}	AVE ^{****)}
Faith-in- spired inter- relational citizenship	1. Religiosity			0,891	0,925	0,754
	Confidence level	CL	0,848			
	Religious practice	RP	0,874			
	Participation in religious activities	PR	0,906			
	Understanding of religious values	URV	0,844			
	2. Citizenship			0,921	0,941	0,761
	Political participation	PP	0,890			
	Legal compliance	LC	0,858			
	Social participation	SP	0,857			
	Political awareness	PA	0,934			
	3. Interfaith cooperation			0,897	0,917	0,733
	Interreligious dialogue	ID	0,833			
	Collaboration in social projects	CSR	0,869			
	Interfaith education and awareness	IEA	0,868			
	Joint activities in religious events	JAR	0,854			
Awareness of mission	Understanding of humanity's challenges	UGC	0,838	0,879	0,916	0,732

calls for hu- manity:	Awareness of personal involve- ment	API	0,850	0,866	0,909	0,714
	Knowledge of humanitarian or- ganizations and initiatives	KHO	0,871			
	Motivation for humanitarian ac- tion	MHA	0,863			
Meaningful life	Social connection	SC	0,874	0,866	0,909	0,714
	Achievements and contributions	AC	0,845			
	Meaning and value	MV	0,856			
	Personal growth	PG	0,874			
Spiritual engagement	Religious practices	URP	0,828	0,827	0,885	0,658
	The search for meaning	SM	0,828			
	Religious community	RC	0,834			
	Ethics and values	EV	0,787			
Prosocial engagement	Religious practices	URP	0,828	0,877	0,916	0,731
	The search for meaning and un- derstanding	SMU	0,861			
	Connection with nature or tran- scendental power	CNT	0,839			
	Application of spiritual values and ethics	ASV	0,890			
Local and religious values	1. Justice			0,908	0,923	0,523
	Equality and fair treatment	EVT	0,880			
	Participation and equal oppor- tunity	PEO	0,870			
	Transparency and accountability	TA	0,915			
	Law and human rights	AHR	0,886			
	2. Peace			0,898	0,929	0,766
	Nonviolence	NV	0,850			
	Justice and equality	JE	0,880			
	Dialogue and diplomacy	DD	0,882			
	Sustainable development	SD	0,888			
	3. Social integration			0,873	0,913	0,724
	Community Membership	CM	0,856			
	Social network	SN	0,844			
	Political and civil participation	PCP	0,863			
Inclusion and acceptance	IA	0,841				

*)stacking calculate ought to be more than 0.7; **)Cronbach's Alpha ought to be more than 0.7; ***). Composite unwavering quality ought to be more than 0.7; ****)AVE ought to be more than 0.5

Based on Figure 1 and Table 3, it can be seen that more than 70% of the fluctuation of each marker can be clarified by the factors of this ponder. In this way, in general, each idle variable can explain the information change. The composite unwavering quality esteem of the five inactive factors and their measurements features a composite unwavering quality esteem over 0.6. That is, the built-up pointers can degree each fixed variable well, or it can be said that the five estimation models are solid. The tall relationship between indicators that make up the development also appears to have great concurrent legitimacy esteem. The AVE esteem of the five inactive factors features affection over the slightest basis, which is 0.5, so the degree of concurrent legitimacy is excellent or can be said to meet the focalized

legitimacy criteria. The other measure is discriminant legitimacy, by comparing the relationship between builds with the roots of AVE or Fornell-Lacker Criteria in Table 4.

Table 4: Fornell-Lacker Criteria

Path	Awareness of the mission calls for humanity	Faith-inspired inter-relational citizenship	Local and religious values	Meaningful life	Prosocial engagement	Spiritual engagement
Awareness of the mission calls for humanity	0,856					
Faith-inspired inter-relational citizenship	0,484	0,698				
Local and religious values	0,575	0,671	0,723			
Meaningful life	0,513	0,640	0,739	0,845		
Prosocial engagement	0,461	0,596	0,718	0,610	0,855	
Spiritual engagement	0,465	0,609	0,814	0,694	0,685	0,811

***Fornell-Lacker Criteria ought to be more than the relationship esteem of that develop to. The values run from 1, where the next affection shows a higher unwavering quality level. In exploratory inquiries, values of composite reliability/Cronbach alpha between 0.60 to 0.70 are worthy, whereas in more advanced arrange the esteem got to be higher than 0.70.

Based on Table 4 above, all constructs meet the Fornell Lacker criteria, indicating that all constructs are valid and reliable.

Inner Model Assessment

Test the possibility of the demonstration utilizing the r-square esteem. The result of the r-square esteem investigation for Faith-Inspired Inter-Relational Citizenship was 0.506. The figure clarifies that the inconstancy of endogenous factors can be defined by the changeability of exogenous factors of 50.6%, whereas the r-square esteem for Neighborhood and Devout Values is 0.773. The figure clarifies that the inconsistency of endogenous factors can be defined by the change of exogenous factors of 77.3%. In expansion to r-square, an examination was carried out on the impact of exogenous factors on known endogenous factors based on the esteem of impact measure f-square and q-square displayed in Figure 1 and Table 5 below.

Tabel 5: r-square, f-square, and q-square

Construct	r-square*)	f-square**)	Q-square ***)
Faith-Inspired Inter-Relational Citizenship	0,506	0,532	0,234
Local and Religious Values	0,773	0,626	0,396

*)path with r-square less than 0.5 is considered weak predictive accuracy; **)A path with an f-square above 0.35 is considered large; *)A **)path q-square of more than 0.25 is considered medium predictive relevance

The faith-inspired inter-relational citizenship variable (r-square = 0.506) had a lower contribution than local and religious values (r-square = 0.773), while the q-square variable local and religious values (0.396) had higher predictive validity than the faith-inspired inter-relational citizenship variable (q-square = 0.396). Thus, it can be concluded that local and religious values have a higher contribution in explaining variations in faith-inspired inter-relational citizenship based on higher r-square values. In addition, these two variables have relatively good predictive validity based on positive q-square values.

Table 5 data shows that kinship has a significant impact in shaping the social structure and cultural values of Indonesian society. It creates a strong sense of attachment between family members and provides the basis for widespread social solidarity in everyday life. Kinship strength, often referred to as family strength or family relationships, has an important role in Indonesian society. Indonesia is a country with a culture that attaches great importance to family values, intergenerational solidarity, and emotional attachment between family members.

Hypothesis Testing

The results of the path coefficient (path beta) and t-statistic values obtained through the bootstrapping process with a sample number of 234 are shown in Figure 1 and Table 6 as follows.

Table 6: Path beta, t-value, and P-value

Path	Path beta	t-value	P-value	Result
Awareness of mission calls for humanity → faith-inspired inter-relational citizenship	0,141	2,403	0,017	Accepted
Awareness of the mission calls for humanity → local and religious values	0,143	2,972	0,003	Accepted
Meaningful life → faith-inspired inter-relational citizenship	0,312	4,148	0,000	Accepted
Meaningful life → local and religious values	0,187	2,927	0,004	Accepted
Prosocial engagement → faith-inspired inter-relational citizenship	0,220	3,415	0,001	Accepted
Prosocial engagement → local and religious values	0,177	2,526	0,012	Accepted
Spiritual engagement → faith-inspired inter-relational citizenship	0,176	2,396	0,017	Accepted
Spiritual engagement → local and religious values	0,424	6,909	0,000	Accepted
Faith-inspired inter-relational citizenship → local and religious values	0,119	2,334	0,020	Accepted

Table 6 displays the influence of Awareness of Mission Calls for Humanity on faith-inspired inter-relational citizenship (0.141 with a p-value of 0.017) and local and religious values (0.143 with a p-value of 0.003). It also demonstrates the influence of Meaningful Life on faith-inspired interrelational citizenship (0.312 with a p-value of 0.000) and local and religious values (0.187 with a p-value of 0.004). Furthermore, it showcases the impact of Prosocial Engagement on faith-inspired inter-relational citizenship (0.220 with a p-value of 0.005) and local and religious values (0.177 with a p-value of 0.012). The influence of Spiritual Engagement on faith-inspired inter-relational citizenship is indicated as 0.176 with a p-value of 0.017 and on local and religious values as 0.424 with a p-value of 0.000. Additionally, it illustrates the influence of faith-inspired inter-relational citizenship on local and religious values as 0.119 with a p-value of 0.020. According to (J. F. Hair et al., 2019), if $p < 0.05$, the alternative hypothesis (H_a) is accepted. This implies that all nine proposed hypotheses can be considered to have a significant effect..

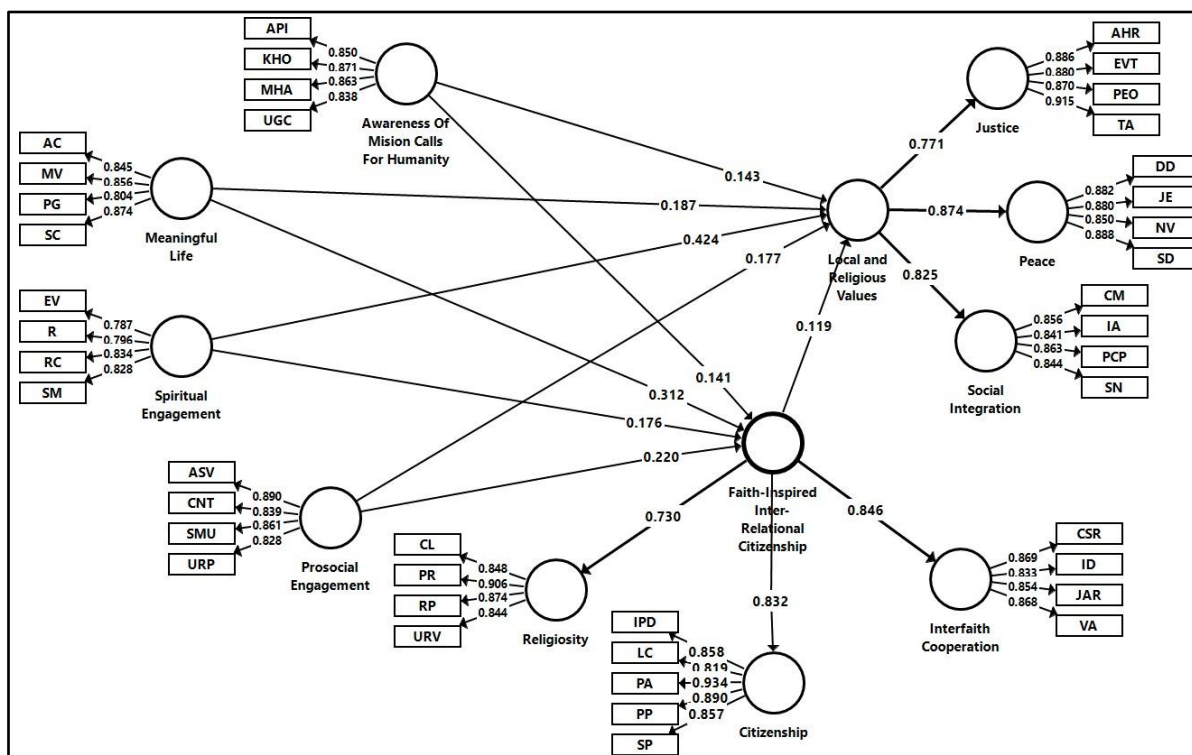

Figure 1: Path diagram and loading factor values

Discussion for Quantitative Result:

These findings reveal that awareness of humanitarian mission vocations, meaningful living, prosocial engagement, and spiritual involvement exerts a positive and significant influence on faith-inspired inter-relational citizenship and local and religious values. Furthermore, faith-inspired inter-relational citizenship positively and significantly impacts local and spiritual values. These results underscore the profound dimension within the relationship between Mission Awareness Calling for Humanity and Faith-Inspired Inter-Relational Citizenship (Arshad et al., 2020; Baldassarri & Abascal, 2020). Educators acknowledge that fostering awareness of global challenges among students can be facilitated by instilling faith-inspired inter-relational values. This approach seamlessly integrates spiritual principles, enhancing empathy and cooperation across diverse cultures. Educators discern the potential in religious teachings to fortify students' dedication to effecting positive societal change. However, concerns persist regarding potential exclusivity and value conflicts stemming from these efforts. (FioRito et al., 2021; Piatak & Holt, 2019; Preston et al., 2010; Saroglou, 2012; Silke et al., 2018; Tsang et al., 2021).

6. Results of Qualitative Analysis

This report delves into the rich insights educators from diverse educational backgrounds provide regarding the intricate relationships between leading a meaningful life and embracing faith-based inter-relational citizenship. The primary objective of this exploration is to gain a deeper understanding of how educators perceive the role of religious principles in fostering cross-community cooperation. To achieve this, semi-structured interviews were conducted with the participants.

Meaningful Life

Participants A (representing Islam), B (Christianity), and C (Buddhism) offer profound perspectives on the concept of a meaningful life, as viewed through the lenses of their respective faiths and personal values. Islamic teachings emphasize the importance of service and purpose; Christianity integrates faith into action, while Buddhism places a strong emphasis on introspection. Despite these distinct approaches, a common thread emerges – a shared human yearning for purpose, values, and self-

awareness. This exploration underscores a universal desire to transcend religious boundaries and prompts questions about how these perspectives influence individuals' responses to life's challenges and their contributions to society.

Awareness of Mission Calls for Humanity

Perspectives from Participants A (Islam), B (Christianity), and C (Buddhism) delve into the significance of nurturing relationships grounded in human values and empathy, albeit through different religious prisms. Islam advocates global brotherhood and underscores the worth of heart through the concept of a humanitarian mission. Christianity emphasizes the call to create harmony and togetherness among people, reflected in Christian values such as love and inclusivity, where faith-driven actions contribute to a mutually supportive society. On the other hand, Buddhism places great importance on consciousness in forming connections between individuals, with compassion as a driving force for actively improving social and humanitarian conditions.

Prosocial Engagement

Perspectives of Participants A (Islam), B (Christianity), and C (Buddhism) delve into the significance of engaging in positive actions that promote social welfare, albeit through varying religious lenses. Islam highlights the importance of proactive social engagement in aiding others and enhancing societal conditions, aligning with Islamic teachings on 'Alms' and service to create a positive community impact. In bold actions, Christianity underscores the significance of love and concern for others' needs, reflecting Christian values such as "loving your neighbor," which advocate selfless giving. Buddhism emphasizes the role of empathy and conscious concern in pro-social actions, consistent with the principle of compassion, encouraging individuals to prioritize the welfare of others and contribute to the common good.

Spiritual Engagement

Participants A (Islam), B (Christianity), and C (Buddhism) investigate the noteworthiness of otherworldly engagement as an implication to achieve peace, reflection, and individual development, with significant suggestions for one's relationship with God or the universe. Islam advances otherworldly associations to draw closer to God and discover life's meaning, with exercises like supplication, dhikr, and tafakur seen as roads for inward peace and fortifying the Creator's relationship. Christianity underscores otherworldly engagement as a profound association with God through supplication, reflection, and reflection on God's Word, cultivating closeness to God and phenomenal development. Buddhism highlights supernatural association as an exertion toward illumination and self-awareness, with contemplation and profound reflection supporting an understanding of the nature of enduring and accomplishing internal peace.

Faith-Inspired Relational Citizenship

Participants A (Islam), B (Christianity), and C (Buddhism) offer viewpoints on faith-inspired inter-relational citizenship, emphasizing the part of otherworldly values in manufacturing a concordant society. Speaking to Islam, Member A emphasizes all-inclusive brotherhood and sympathy over social contrasts. Member B, the Christian teacher, underscores the significance of cherishing and inclusivity inside a Christian system. Member C, speaking to Buddhism, sees inter-relational citizenship as an implication to address societal issues through kindness and connectedness. This point of view calls for appreciating humanity's solidarity and the greatness of contrasts, possibly forming a comprehensive and collaborative vision for society. Assist investigation of how confidence rouses beneficial societal activities remains an interesting road inside an instructive setting.

Local and Religious Values

Participants A (Islam), B (Christianity), and C (Buddhism) express their points of view on the part of neighborhood and devout values in forming individuals' morals, ethics, and societal well-being. Islam underscores the centrality of nearby and holy values in developing solid character and ethics, with values like trustworthiness, support, and sympathy shaping the bedrock of the standard of living. Christianity highlights the keenness of neighborhood and devout values in forming morals and behavior, with matters such as adore, kindness, and obligation toward others serving as the establishment for tending to life's challenges. Buddhism underscores the part of neighborhood and devout values in

cultivating inward peace and well-being, with values like resilience, persistence, and regard for all creatures essential to accomplishing peace of intellect.

Discussion for Qualitative Result

These compelling findings show that awareness of humanitarian mission vocations, meaningful living, prosocial engagement, and spiritual involvement will positively influence faith-inspired inter-relational citizenship and local and religious values. Furthermore, it's important to note that faith-inspired inter-relational citizenship significantly and positively impacts local and spiritual values. These discoveries unveil the profound dimensions within the relationship between Mission Awareness Calling for Humanity and Faith-Inspired Inter-Relational Citizenship. (Zaenuddin et al. 2022b; Huber and Huber 2012; McDaniel 2015; Khozin 2013).

Educators wholeheartedly recognize the potential of instilling faith-inspired inter-relational values in students. They understand this approach integrates spiritual principles, fostering empathy and cooperation across diverse cultures. Moreover, educators see the power of religious teachings to bolster students' commitment to effecting positive societal change. However, they remain vigilant about exclusivity or clashes among belief systems. Striking a balance between these aspects, educators appreciate the synergy between mission awareness and faith-driven inter-relational citizenship, which serves as a platform for meaningful dialogue and collaborative action, ultimately shaping responsible global citizens (McDaniel, 2015; Zaenuddin et al., 2022).

The correlation between Mission Awareness, Calling for Humanity, and Local and Religious Values is multifaceted. Educators acknowledge that integrating local and religious values can enrich students' understanding of global challenges, grounding them in cultural heritage. Nevertheless, concerns about potential bias or exclusion stemming from diverse value systems have arisen. Educators emphasize the necessity for an inclusive approach that respects differences in faith while fostering collective responsibility. These connections offer a unique avenue to engage students, aligning global missions with personal values. By promoting critical thinking and respectful dialogue, educators envision a harmonious equilibrium between awareness, deals, and active participation in addressing human needs (Zaenuddin et al. 2022b; Huber and Huber 2012; McDaniel 2015; Khozin 2013).

The relationship between leading a Meaningful Life and Faith-Inspired Inter-Relational Citizenship offers profound insights. Integrating faith-based inter-relational principles enhances students' pursuit of a purposeful life, fostering empathy, cultural understanding, and a sense of belonging. However, educators remain attentive to concerns regarding potential exclusivity or dogmatism. They underscore the importance of encouraging critical thinking and open-mindedness while nurturing students' spiritual growth. These connections provide a framework for students to channel their beliefs into positive interactions, contribute to meaningful lives through collective engagement, transcend boundaries, and foster a broader sense of purpose and satisfaction.

Moreover, serious thought is encouraged by the nexus of faith-inspired inter-relational citizenship and prosocial engagement. Teachers recognize that inter-relational values based on faith frequently cause children to act more prosocially, promoting empathy, cooperation, and a sense of duty toward others. However, worries about conflicts resulting from different religious systems have been voiced. Instructors emphasize the importance of inclusive interpretations that uphold individual beliefs while fostering togetherness. These connections light how students can incorporate their values into deeds of virtue, create a culture that positively affects society by embracing diversity, lead by example, and provide an example of kindness.

The connection between prosocial engagement and local and religious values offers a critical viewpoint. Educators acknowledge that local and religious values frequently encourage students to exhibit heightened prosocial behavior, nurturing compassion, community involvement, and ethical responsibility. However, concerns have been raised about potential clashes among different value systems. Educators advocate for inclusive teaching that celebrates diversity while fostering unity. These connections offer a platform for students to align their personal beliefs with acts of kindness, thereby contributing to a more compassionate society. Educators underscore the importance of fostering empathy and promoting respectful dialogue, enabling students to embody shared values while

embracing their individual religious beliefs (Zaenuddin et al. 2022b; Huber and Huber 2012; McDaniel 2015; Khozin 2013).

Views on the interaction between Spiritual Engagement and Faith-Inspired Inter-Relational Civic Engagement reveal profound reflection. Educators recognize that faith-driven interrelational values often lead to deeper spiritual connections, fostering empathy, understanding, and a sense of shared humanity. Nevertheless, concerns about the potential for exclusivity or bias associated with diverse beliefs have been raised. Teachers advocate for cultivating open-mindedness and respectful discourse while nurturing students' spiritual growth. These relationships highlight avenues for students to channel their ideas into positive interactions, contribute to a meaningful existence by transcending boundaries, embracing diversity, and collectively cultivating a sense of spiritual fulfillment through compassionate engagement.

7. Conclusion

This research passionately reveals that awareness of humanitarian mission vocations, meaningful living, prosocial engagement, and spiritual involvement wielded a remarkably positive and significant influence on faith-inspired inter-relational citizenship and local and religious values. These groundbreaking findings illuminated the profound and intricate dimensions of the relationships among these crucial elements. Educators enthusiastically embraced the immense value of infusing faith-inspired inter-relational principles into education, recognizing the potential to elevate students' awareness of global challenges, nurture empathy, and foster cross-cultural cooperation. Nonetheless, they astutely flagged potential challenges, including the risk of exclusivity and conflicts of values in these transformative endeavors.

Yet, it must be acknowledged that this study grappled with several limitations. Primarily, it focused exclusively on the perspectives of educator managers, inadvertently neglecting the invaluable insights of other education practitioners, potentially constraining the breadth of our understanding. Furthermore, the bulk of findings relied heavily on educators' viewpoints, with no quantification of real-world student behavior. Lastly, due to the study's confined scope to a specific locale, the generalizability of its findings to broader contexts remained somewhat restricted. To rectify these shortcomings, future research endeavors should delve deeper into the tangible impact of integrating religiously inspired inter-relational values into education. This would involve investigating the practical implementation of these principles in schools, rigorously measuring behavioral shifts in students, and assessing the long-term effects on the development of responsible global citizens. Moreover, expanding the study's scope to include a larger, more diverse sample and a broader array of religious perspectives would undoubtedly enhance the comprehensiveness of this framework.

References

- Acharoui, Zakia, Altaf Alaoui, Badia Ettaki, Jamal Zerouaoui, and Mohamed Dakkon. 2020. 'Identifying Political Influencers on YouTube during the 2016 Moroccan General Election'. *Procedia Computer Science* 170 (2018): 1102–9. <https://doi.org/10.1016/j.procs.2020.03.061>.
- Adon, Mathias Jebaru, and Antonius Denny Firmanto. 2022. 'Makna Belas Kasih Allah Dalam Hidup Manusia Menurut Henri JM Nouwen'. *Dunamis : Jurnal Teologi Dan Pendidikan Kristiani* 6 (2): 581–603.
- Agudelo, César Augusto Ruiz, and Angela María Cortes-Gómez. 2021. 'Sustainable Behaviors, Prosocial Behaviors, and Religiosity in Colombia. A First Empirical Assessment'. *Environmental Challenges* 4 (1): 1–12. <https://doi.org/10.1016/j.envc.2021.100088>.
- Ahmadi-Gh, Zahra, and Alejandro Bello-Pintado. 2022. 'Why Is Manufacturing Not More Sustainable? The Effects of Different Sustainability Practices on Sustainability Outcomes and Competitive Advantage'. *Journal of Cleaner Production* 337: 130392. <https://doi.org/10.1016/j.jclepro.2022.130392>.

- Apostolopoulos, Nikolaos, Robert Newbery, and Menelaos Gkartzios. 2018. 'Social Enterprise and Community Resilience : Examining a Greek Response to Turbulent Times'. *Journal of Rural Studies*, no. March: 1–10. <https://doi.org/10.1016/j.jrurstud.2018.03.017>.
- Arshad, Muhammad, Ghulam Abid, Francoise Venezia, and Contreras Torres. 2020. 'Impact of Prosocial Motivation on Organizational Citizenship Behavior'. *Quality & Quantity* 55 (1): 133–50. <https://doi.org/10.1007/s11135-020-00997-5>.
- Aydin Sünbül, Zeynep. 2021. 'Indirect Relations of Mindful Awareness with Different Forms of Prosocial Actions within College Students: The Mediating Role of Empathy'. *Current Psychology* 40 (1): 126–32. <https://doi.org/10.1007/s12144-019-00342-6>.
- Baldassarri, Delia, and Maria Abascal. 2020. 'Diversity and Prosocial Behavior'. *Science* 369 (4 September 2020): 1183–87.
- Banusu, Yakobus Ori, and Antonius Denny Firmanto. 2020. 'Kebahagiaan Dalam Ruang Keseharian Manusia'. *Forum* 49 (2): 51–61. <https://doi.org/10.35312/forum.v49i2.301>.
- Barokah, F, and H Hertanto. 2020. 'Disrupsi Politik: Peluang Dan Tantangan Partai Politik Baru Jelang Pemilu 2024'. *Nakhoda: Jurnal Ilmu Pemerintahan* 21 (1): 1–3.
- Batson, C. Daniel, Kathryn C. Oleson, Joy L. Weeks, Sean P. Healy, Penny J. Reeves, Patrick Jennings, and Thomas Brown. 1989. 'Religious Prosocial Motivation: Is It Altruistic or Egoistic?' *Journal of Personality and Social Psychology* 57 (5): 873–84. <https://doi.org/10.1037/0022-3514.57.5.873>.
- Bernt, Frank M. 1989. 'Being Religious and Being Altruistic: A Study of College Service Volunteers'. *Personality and Individual Differences* 10 (6): 663–69. [https://doi.org/10.1016/0191-8869\(89\)90225-0](https://doi.org/10.1016/0191-8869(89)90225-0).
- Buigut, Steven, and Brain Masinde. 2021. 'The Impact of General Elections on Kenya' s Tourism, Financial, and Media Sector'. *Journal of African Business*, 1–19. <https://doi.org/10.1080/15228916.2021.1874793>.
- Cappellen, Patty Van, Barbara L. Fredrickson, Vassilis Saroglou, and Olivier Corneille. 2017. 'Religiosity and the Motivation for Social Affiliation'. *Personality and Individual Differences* 113: 24–31. <https://doi.org/10.1016/j.paid.2017.02.065>.
- Caprara, Gian Vittorio, Patrizia Steca, Arnaldo Zelli, and Cristina Capanna. 2005. 'A New Scale for Measuring Adults' Prosocialness'. *European Journal of Psychological Assessment* 21 (2): 77–89. <https://doi.org/10.1027/1015-5759.21.2.77>.
- Cret, Remus. 2021. "'You Become One With The Place": Social Mixing, Social Capital, and the Lived Experience of Urban Desegregation in the Roma Community'. *Cities* 117 (2020): 1–10. <https://doi.org/10.1016/j.cities.2021.103302>.
- Epitropaki, Olga, and Robin Martin. 2005. 'From Ideal to Real: A Longitudinal Study of the Role of Implicit Leadership Theories on Leader-Member Exchanges and Employee Outcomes'. *Journal of Applied Psychology* 90 (4): 659–76. <https://doi.org/10.1037/0021-9010.90.4.659>.
- Fadilah, G. 2021. 'Implikasi Teori-Teori Konflik Terhadap Realitas Sosial Masa Kini: Tinjauan Pemikiran Para Tokoh Sosiologi.' *Journal of Society and Development* 13 (1): 11–15.
- FioRito, Taylor A., Clay Routledge, and Jeremy Jackson. 2021. 'Meaning-Motivated Community Action: The Need for Meaning and Prosocial Goals and Behavior'. *Personality and Individual Differences* 171 (1). <https://doi.org/10.1016/j.paid.2020.110462>.
- Firmanto, A.D. 2017. 'Kehadiran Gereja Di Ruang Publik Perspektif Eklesiologis Di Dalam Memandang Keadaan Akhir-Akhir Ini'. *Seri Filsafat Teologi Widaya Sahana* 27: 272–85.
- . 2021a. 'Katekese Virtual Kepada Korban Bencana Alam Di Masa Pandemi Menurut Model Berteologi Kosuke Koyama'. *Religious (Jurnal Studi Agama-Agama Dan Lintas Budaya)* 5 (2): 255–70.
- . 2021b. 'WhatsApp Group Sebagai Ruang Percakapan Pastoral Di Masa Pandemi Covid-19'. *Dunamis – Jurnal Teologi Dan Pendidikan Kristiani* 6 (2): 480–95.
- Gallie, D, Y Zhou, A Felstead, F Green, and G Henseke. 2017. 'The Implications of Direct Participation for Organisational Commitment, Job Satisfaction, and Affective Psychological Well-Being: A Longitudinal Analysis'. *Industrial Relations Journal* 48 (2): 174–91.
- Gannon, Brenda, and Jennifer Roberts. 2018. 'Social Capital: Exploring the Theory and Empirical Divide'. *Empirical Economics*, 1–21. <https://doi.org/10.1007/s00181-018-1556-y>.

- Ganzevoort, R. Ruard, and Johan Roeland. 2014. 'Lived Religion: The Praxis of Practical Theology'. *International Journal of Practical Theology* 18 (1): 91–101. <https://doi.org/10.1515/ijpt-2014-0007>.
- Ghosh, Indrajit, and Maia Martcheva. 2021. 'Modeling the Effects of Prosocial Awareness on Covid-19 Dynamics: Case Studies on Colombia and India'. *Nonlinear Dynamics* 104 (4): 4681–4700. <https://doi.org/10.1007/s11071-021-06489-x>.
- Ghozali, I. 2011. *Structural Equation Modeling Metode Alternatif Dengan Partial Least Square (PLS) Edisi 3*. Badan Penerbit Universitas Diponegoro.
- González-neira, Ana, and Erica Conde-vázquez. 2020. 'Spanish Audience Interest in Televised Politics: From Electoral Debates to Politainment'. *Communication & Society* 33 (3): 85–100. <https://doi.org/10.15581/003.33.3.85-100>.
- Groot, Judith De, and Linda Steg. 2009. 'Morality and Prosocial Behavior: The Role of Awareness, Responsibility, and Norms in the Norm Activation Model'. *Journal of Social Psychology* 149 (4): 425–49. <https://doi.org/10.3200/SOCP.149.4.425-449>.
- Hafenbrack, Andrew C, Lindsey D Cameron, Gretchen M Spreitzer, Chen Zhang, Laura J Noval, and Samah Shaffakat. 2019. 'Organizational Behavior and Human Decision Processes Helping People by Being in the Present: Mindfulness Increases Prosocial Behavior'. *Organizational Behavior and Human Decision Processes*, no. 2018: 1–18. <https://doi.org/10.1016/j.obhdp.2019.08.005>.
- Hair, Joe F., Marko Sarstedt, Lucas Hopkins, and Volker G. Kuppelwieser. 2014. 'Partial Least Squares Structural Equation Modeling (PLS-SEM): An Emerging Tool in Business Research'. *European Business Review* 26 (2): 106–21. <https://doi.org/10.1108/EBR-10-2013-0128>.
- Handoko, Susanto T. 2020. 'Kearifan Lokal Sebagai Modal Sosial Dalam Mengembangkan Perdamaian Di Papua'. *MASA : Journal of History* 1 (2): 94–113. <https://doi.org/10.31571/masa.v1i2.1633>.
- Hendricks, La Velle, Willie Edwards, Tara Tietjen-Smith, and Stephen Reysen. 2022. 'College Students' Awareness and Familiarity with Modern Activism: Prosocial Involvement in Black Lives Matter'. *Journal of Human Behavior in the Social Environment* 32 (4): 534–47. <https://doi.org/10.1080/10911359.2021.1924914>.
- Hilbig, Benjamin E., Andreas Glöckner, and Ingo Zettler. 2014. 'Personality and Prosocial Behavior: Linking Basic Traits and Social Value Orientations'. *Journal of Personality and Social Psychology* 107 (3): 529–39. <https://doi.org/10.1037/a0036074>.
- Huber, Stefan, and Odilo W. Huber. 2012. 'The Centrality of Religiosity Scale (CRS)'. *Religions* 3 (3): 710–24. <https://doi.org/10.3390/rel3030710>.
- Iannone, Aniello. 2022. 'Democracy Crisis in South-East Asia: Media Control , Censorship, and Disinformation during the 2019 Presidential and General Elections in Indonesia, Thailand and 2019 Local Election in the Philippines'. *Jurnal Ilmu Sosial Dan Ilmu Politik* 26 (1): 81–97.
- Ikmal, Mohamad, and Mohamad Arifin. 2020. 'Anarkisme Politik Di Aras Lokal (Peran "Bandit" Politik Dalam Pilkada Di Kabupaten Sumenep)'. *Jurnal Ilmu Politik Dan Pemerintahan* 6 (2): 123–52.
- Jena, L.K. 2014. 'Workplace Spirituality and Work-Life Balance'. *International Journal of Applied Psychology* 4 (4): 155–61. <https://doi.org/10.5923/j.ijap.20140404.04>.
- Kasim, Fajri M, Abidin Nurdin, and M Rizwan. 2021. 'Agama, Modal Sosial Dan Ketahanan Masyarakat Dalam Menghadapi Bencana Di Kota Banda Aceh'. *Jurnal Antropologi: Isu-Isu Sosial Budaya* 23 (1): 66. <https://doi.org/10.25077/jantro.v23.n1.p66-73.2021>.
- Kharlie, Ahmad Tholabi. 2023. "'Civil Society" Dan Penguatan Nilai Kemanusiaan'. *Kompas*, 2023.
- Khozin, Wahid. 2013. 'Sikap Keagamaan Dan Potensi Radikalisme Agama Mahasiswa Perguruan Tinggi Agama'. *Edukasi: Jurnal Penelitian Pendidikan Agama Dan Keagamaan* 11 (3): 289–304. <https://doi.org/10.32729/edukasi.v11i3.415>.
- Kim, Haemi, and Hailin Qu. 2020. 'The Mediating Roles of Gratitude and Obligation To Link Employees' Social Exchange Relationships and Prosocial Behavior'. *International Journal of Contemporary Hospitality* 32 (2): 644–64. <https://doi.org/10.1108/IJCHM-04-2019-0373>.
- Knudsen, Eirik Sjøholm, Lasse B. Lien, Bram Timmermans, Ivan Belik, and Sujit Pandey. 2021. 'Stability in Turbulent Times? The Effect of Digitalization on the Sustainability of Competitive Advantage'. *Journal of Business Research* 128 (February): 360–69. <https://doi.org/10.1016/j.jbusres.2021.02.008>.

- Kurnia, Novi, and Santi Indra Astuti. 2017. 'Peta Gerakan Literasi Digital Di Indonesia: Studi Tentang Pelaku, Ragam Kegiatan, Kelompok Sasaran Dan Mitra'. *Informasi: Kajian Ilmu Komunikasi* 47 (2): 149–66. <https://doi.org/10.21831/informasi.v47i2.16079>.
- Lambert, Nathaniel M., Tyler F. Stillman, Joshua A. Hicks, Shanmukh Kamble, Roy F. Baumeister, and Frank D. Fincham. 2013. 'To Belong Is to Matter: Sense of Belonging Enhances Meaning in Life'. *Personality and Social Psychology Bulletin* 39 (11): 1418–27. <https://doi.org/10.1177/0146167213499186>.
- Lee, Juheon. 2019. 'Bonding and Bridging Social Capital And Their Associations With Self - Evaluated Community Resilience: A Comparative Study of East Asia'. *Journal of Community and Applied Social Psychology*, no. March: 1–14. <https://doi.org/10.1002/casp.2420>.
- Letsoin, Y.S., A.D. Firmanto, and N.W Aluwesia. 2021. 'Gereja Partisipatif-Memasyarakat Di Tengah Pandemi Covid-19'. *Media: Jurnal Filsafat Dan Teologi* 3 (2): 221–38.
- Li, Kaijian, Ruopeng Huang, Guiwen Liu, and Asheem Shrestha. 2022. 'Social Capital in Neighbourhood Renewal : A Holistic and State of the Art Literature Review'. *Land* 11 (1202): 1–27.
- Lord, Robert G., Paola Gatti, and Susanna L.M. Chui. 2016. 'Social-Cognitive, Relational, and Identity-Based Approaches to Leadership'. *Organizational Behavior and Human Decision Processes* 136: 119–34. <https://doi.org/10.1016/j.obhdp.2016.03.001>.
- Manala, Matsobane J. 2018. 'Gratitude as a Christian Lifestyle: An Afro-Reformed Theological Perspective'. *HTS Teologiese Studies / Theological Studies* 74 (4): 1–8. <https://doi.org/10.4102/hts.v74i4.5117>.
- McDaniel, June. 2015. 'Indonesia, Modernity and Some Problems of Religious Adaptation'. *Wacana* 15 (2): 314. <https://doi.org/10.17510/wacana.v15i2.406>.
- Meng, Jie. 2022. 'The More We Know, The More Likely We May Agree?' *Telematics and Informatics* 70 (September 2021): 101807. <https://doi.org/10.1016/j.tele.2022.101807>.
- Mikovi, Radmila, Dejan Petrovi, Marko Mihi, Vladimir Obradovi, and Marija Todorovi. 2020. 'The Integration of Social Capital and Knowledge Management – The Key Challenge For International Development and Cooperation Projects of Nonprofit Organizations'. *International Journal of Project Management* 10: 1–19. <https://doi.org/10.1016/j.ijproman.2020.07.006>.
- Mittal, Rakesh, and Peter W. Dorfman. 2012. 'Servant Leadership Across Cultures'. *Journal of World Business* 47 (4): 555–70. <https://doi.org/10.1016/j.jwb.2012.01.009>.
- Murray, Brittany, and Amy Petts. 2020. '“We’re in This Together”: Bridging and Bonding Social Capital in Elementary School PTOs'. *American Educational Research Journal* 20 (10): 1–35. <https://doi.org/10.3102/0002831220908848>.
- Mustapha, Lambe Kayode, and Bahiyah Omar. 2020. 'Do Social Media Matter? Examining Social Media Use And Youths’ Political Participation During The 2019 Nigerian General Elections'. *The Round Table* 109 (4): 441–57. <https://doi.org/10.1080/00358533.2020.1788766>.
- Mustapha, Lambe Kayode, Bahiyah Omar, Fitria Barokah, Tabah Maryanah, Ari Darmasturi, Matthew Warren, Zakia Acharoui, et al. 2020. 'Spanish Audience Interest in Televised Politics: From Electoral Debates to Politainment'. *Procedia Computer Science* 170 (4): 1–12. <https://doi.org/10.1080/00358533.2020.1788766>.
- Neugebauer, Richard, Priya Wickramaratne, Connie Svob, Clayton H. McClintock, Marc J. Gameroff, Lisa Miller, and Anne Conway. 2020. 'Contribution of Religion/Spirituality and Major Depressive Disorder to Altruism'. *Journal of Affective Disorders* 262 (September 2019): 16–22. <https://doi.org/10.1016/j.jad.2019.10.031>.
- Noble, Nicholas Rory Raphael. 2020. 'Paideia as Pious Preparation'. *Norwegian School of Theology*.
- Pfattheicher, Stefan, Yngwie Asbjørn Nielsen, and Isabel Thielmann. 2022. 'Prosocial Behavior and Altruism: A Review of Concepts and Definitions'. *Current Opinion in Psychology* 44: 1–15. <https://doi.org/10.1016/j.copsyc.2021.08.021>.
- Piatak, Jaclyn S, and Stephen B Holt. 2019. 'Prosocial Behaviors: A Matter of Altruism or Public Service Motivation?' *Journal of Public Administration Research and Theory*, 1–15. <https://doi.org/10.1093/jopart/muz041>.

- Preston, Jesse Lee, Ryan S. Ritter, and J. Ivan Hernandez. 2010. 'Principles of Religious Prosociality: A Review and Reformulation'. *Social and Personality Psychology Compass* 4 (8): 574–90. <https://doi.org/10.1111/j.1751-9004.2010.00286.x>.
- Ramus, Tommaso, Barbara La Cara, Antonino Vaccaro, and Stefano Brusoni. 2018. 'Social or Commercial ? Innovation Strategies in Social Entreprises at Times of Turbulence'. *Business Ethics Quarterly*. <https://doi.org/10.1017/beq.2017.55>.
- Rasdi, Roziah Mohd. 2020. 'Knowledge-Sharing Behaviour in Public Service Organisations: Determinants and the Roles of Affective Commitment and Normative Commitment'. *European Journal of Training and Development*, 1–19. <https://doi.org/10.1108/EJTD-02-2020-0028>.
- Ridge-newman, Anthony. 2020. 'Digital Media As A Driver Of Change In Political Organisation: 2010 And 2015 UK General Elections'. *Media Culture & Society*. <https://doi.org/10.1177/0163443720916398>.
- Routledge, Clay, Jamie Arndt, Tim Wildschut, Constantine Sedikides, Claire M. Hart, Jacob Juhl, Ad J.J.M. Vingerhoets, and Wolff Schlotz. 2011. 'The Past Makes the Present Meaningful: Nostalgia as an Existential Resource'. *Journal of Personality and Social Psychology* 101 (3): 638–52. <https://doi.org/10.1037/a0024292>.
- Saroglou, Vassilis. 2012. 'Religion, Spirituality, and Altruism.' *APA Handbook of Psychology, Religion, and Spirituality (Vol 1): Context, Theory, and Research*. 1: 439–57. <https://doi.org/10.1037/14045-024>.
- Saroglou, Vassilis, Magali Clobert, Adam B. Cohen, Kathryn A. Johnson, Kevin L. Ladd, Matthieu Van Pachterbeke, Lucia Adamovova, et al. 2020. 'Believing, Bonding, Behaving, and Belonging: The Cognitive, Emotional, Moral, and Social Dimensions of Religiousness across Cultures'. *Journal of Cross-Cultural Psychology* 51 (7–8): 551–75. <https://doi.org/10.1177/0022022120946488>.
- Sharma, Ankita, and Udayan Ghose. 2020. 'Sentimental Analysis of Twitter Data with Respect to General Elections in India'. *Procedia Computer Science* 173 (2019): 325–34. <https://doi.org/10.1016/j.procs.2020.06.038>.
- Sidler, Petra, Wassilis Kassis, Elena Makarova, and Clarissa Janousch. 2021. 'Assessing Attitudes towards Mutual Acculturation in Multicultural Schools: Conceptualisation and Validation of a Four-Dimensional Mutual Acculturation Attitudes Scale'. *International Journal of Intercultural Relations* 84 (June): 300–314. <https://doi.org/10.1016/j.ijintrel.2021.08.009>.
- Silke, Charlotte, Bernadine Brady, Ciara Boylan, and Pat Dolan. 2018. 'Factors Influencing the Development of Empathy and Pro-Social Behaviour among Adolescents: A Systematic Review'. *Children and Youth Services Review* 94: 421–36. <https://doi.org/10.1016/j.childyouth.2018.07.027>.
- Steger, Michael F., Todd B. Kashdan, Brandon A. Sullivan, and Danielle Lorentz. 2008. 'Understanding the Search for Meaning in Life: Personality, Cognitive Style, and the Dynamic between Seeking and Experiencing Meaning'. *Journal of Personality* 76 (2): 199–228. <https://doi.org/10.1111/j.1467-6494.2007.00484.x>.
- Sukanto, Amos, and S Panca Parulian. 2020. 'Religious Community Responses to the Public Policy of the Indonesian Government Related to the Covid-19 Pandemic' 8: 273–83. <https://doi.org/10.1163/22124810-2020006>.
- Sulphey, M. M., and Ansa Salim. 2021. 'Development of a Tool to Measure Social Entrepreneurial Orientation'. *Journal of Entrepreneurship in Emerging Economies* 13 (2): 231–53. <https://doi.org/10.1108/JEEE-07-2019-0099>.
- Taroreh, Tomy, Antonius Denny Firmanto, and Nanik Wijiyati Aluwesia. 2021. 'Gereja Mengumat Di Masa Pandemi Covid-19'. *JPAK: Jurnal Pendidikan Agama Katolik* 21 (2): 74–96. <https://doi.org/10.34150/jpak.v21i2.300>.
- Tsang, Jo Ann, Rosemary L. Al-Kire, and Juliette L. Ratchford. 2021. 'Prosociality and Religion'. *Current Opinion in Psychology* 40: 67–72. <https://doi.org/10.1016/j.copsyc.2020.08.025>.
- Underwood, Lynn G. 2011. 'The Daily Spiritual Experience Scale: Overview and Results'. *Religions* 2: 29–50. <https://doi.org/10.3390/rel2010029>.
- Untea, Ionut. 2018. 'Contemporary Uses of the Golden Rule of Reciprocity in Abrahamic Interfaith Discourses'. *Studies in Religion-Sciences Religieuses* 47 (1): 107–36. <https://doi.org/10.1177/0008429817721904>.

- Utama, I Wayan Budi. 2012. 'Turbulensi Sosial Dan Membangun Modal Sosial'. *Widyanatya: Jurnal Pendidikan Agama Dan Seni* 2 (1): 63–72.
- Warren, Matthew. 2020. 'Fake News Case Study during the Australian 2019 General Election'. *Australasian Journal of Information Systems* 24: 1–12.
- Wei, Jason, Jian Ng, Gary J Rangel, Yet Chin Phung, Jason Wei, and Jian Ng. 2020. 'Malaysia' s 14th General Election: Dissecting the "Malaysian Tsunami"— Measuring the Impacts of Ethnicity and Urban Development on Electoral Outcomes'. *Asian Journal of Political Science*, 1–25. <https://doi.org/10.1080/02185377.2020.1814363>.
- Xia, Weiwei, Xiaohan Guo, Jun Luo, Hang Ye, Yefeng Chen, Shu Chen, and Weisen Xia. 2021. 'Religious Identity, Between-Group Effects and Prosocial Behavior: Evidence from A Field Experiment in China'. *Journal of Behavioral and Experimental Economics* 91 (January): 101665. <https://doi.org/10.1016/j.socec.2021.101665>.
- Zaenuddin, Dundin, Yekti Maunati, I Ketut Ardhana, and Dicky Sofjan. 2022a. 'A Social Capital in Contemporary Indonesia: Examining Faith-Inspired Civil Society and Democracy'. *Religio: Jurnal Studi Agama-Agama* 12 (2): 211–32. <https://doi.org/10.15642/religio.2022.12.2.211-232>.
- . 2022b. 'Social Capital In Contemporary Indonesia: Examining Faith-Inspired Civil Society and Democracy'. *Religio: Jurnal Studi Agama-Agama* 12 (2): 211–32.
- Zhang, Wei, Sunny Li Sun, Yuan Jiang, and Wenyao Zhang. 2019. 'Openness to Experience and Team Creativity: Effects of Knowledge Sharing and Transformational Leadership'. *Creativity Research Journal* 31 (1): 62–73. <https://doi.org/10.1080/10400419.2019.1577649>.
- Zhi, Sebastian, Tao Khoo, Leong Hock Ho, Ee Hong Lee, Danston Kheng, Boon Goh, Zehao Zhang, Swee Hong Ng, Haodi Qi, and Kyong Jin Shim. 2020. 'Social Media Analytics: A Case Study of Singapore General Election 2020'. In *2020 IEEE International Conference on Big Data*, 5730–32.